

USER'S MANUAL
HAKITEC® 750
with HAKI Trak Sheet ing
Roll-Out Method



Important information

HAKI's product liability and user's manuals apply only to structures that are entirely composed of components that have been made and supplied by HAKI.

HAKI's scaffold systems must not be erected using components of other makes other than HAKI or be connected to scaffolds of makes other than HAKI. In such cases, a special study of load-bearing capacity must be carried out.

Adding components from different suppliers may invalidate the insurance cover.















HAKI reserves the right to make technical modifications on a continual basis.

The latest versions of HAKI user's manuals can be downloaded from our website, www.HAKI.com.

For structures that are not covered by this user's manual, please contact HAKI's technical department.

HAKI colour code

Horizontals and diagonals are marked with their nominal sizes (bay sizes) and a colour code. The marking is a useful means of identification when erecting and handling the scaffold material.

564 	1050 	1964 	3050 
700 	1250 	2050 	3650 
770 	1550 	2500 	4050 
1010 	1655 	2550 	

Forces and dimensions

1000 N = 1 kN ~ 100 kg

10 N ~ 1 kg

All measurements in mm

General description

HAKITEC 750 consists of an aluminium frame, 750 mm high, which is connected together using modular guardrail frames and plan braces.

The frames are joined with two steel connector tubes which are secured with eight 12 mm spring pins.

The entire framework is supported on beam adapters, Y frames and rolling roof wheels.

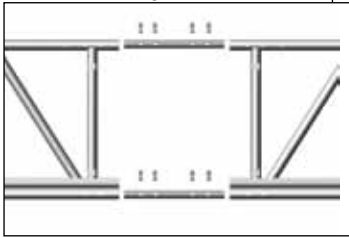
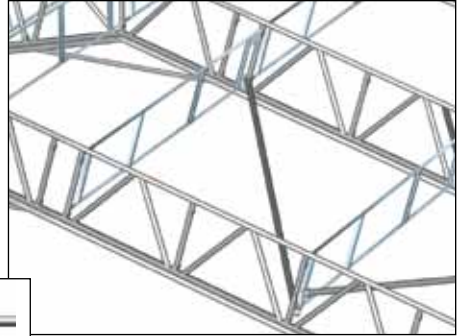

The HAKI Trak system consists of an aluminium alloy extruded track, which is fitted to the top chord of the HAKITEC 750 lattice beam with track clamps which are secured with 12 mm spring pins.

The HAKI Trak tracks are joined with a track joiner and seal which are secured with a track joint plate.

Sheeting is then pulled through the integral slots forming effective weather protection.



General principles

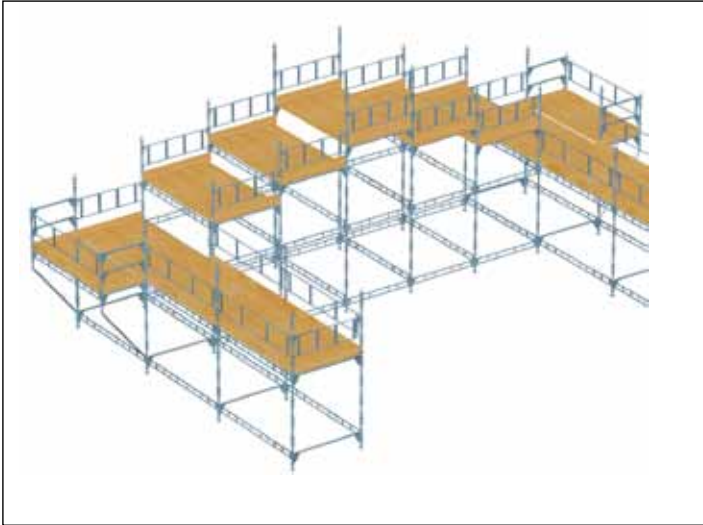

This is a method of erecting a HAKITEC 750 Roof where collective fall prevention is used throughout.

To erect the roof in this manner, a gable scaffold must be provided, with platforms at positions and levels to suit the shape of the full roof truss for the full length of the gable with a working width of 3 m. All platforms should be fully guardrailed, toe boarded on all faces and with adequate safe access.

The temporary roof structure will be built at the gable scaffold and progressively pushed out, bay-by-bay.

This scaffold should include provision for external sheeting bays each side.

The temporary roof, and supporting structure, should be designed by a competent engineer and that the design drawing has considered all appropriate aspects of the roof erection.

Sufficient materials should be at the work-place ready for erection.

The correct number of trained operatives, all personal safety equipment and tools should be available and used.

Whenever any operative cannot work from fully guarded platform, he will attach his lanyard to the HAKITEC 750 lattice beam, preferably to the top chord.

ALL OPERATIONS WILL BE CARRIED OUT FROM SAFE AREAS OF SCAFFOLDING.

Name	Code	Item No.	Weight
Frame 750 AL	750/1250 AL	4032125	9.4
	750/2250 AL	4032225	16.6
	750/3250 AL	4032325	23.9
	750/6250 AL	4032625	44.7

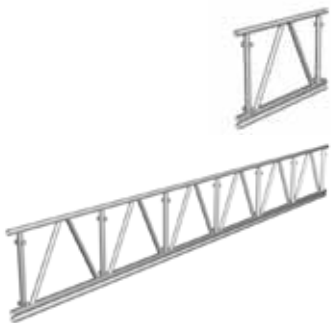

Angle frame 750 AL 15°	750/15 AL	4202260	18.3
----------------------------------	-----------	----------------	------



Angle frame 750 AL 22.5°	750/22.5 AL	4202261	17.6
------------------------------------	-------------	----------------	------



Angle frame 750 AL 37.5°	750/37.5 AL	4202262	16.6
------------------------------------	-------------	----------------	------



Name	Code	Item No.	Weight
Connector tube 750		7203001	2.0



Spring pin	12	2113100	0.1
	16	2116000	0.2



Guardrail frame GFL With spring locking catch Octagon 28 mm	GFL 1250	7052124	5.7
	GFL 1655	7052164	7.4
	GFL 2500	7052254	9.2
	GFL 3050	7052304	10.3

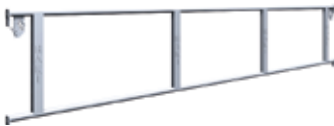

Plan brace 750	2500x2250 AL	4122253	5.1
	2500x2000 AL	4122254	4.9
	3050x2000 AL	4122303	5.5
	3050x2250 AL	4122304	5.6

















Guardrail post 750		7203322	10.5
---------------------------	--	----------------	------









Beam adapter 750 Adjustable to 8-22.5° and 0° Including 2 st Clamping device		7203335	16.8
---	--	----------------	------

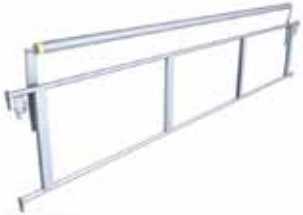

Name	Code	Item No.	Weight
Y frame 750		7203320	10.4
			
Rolling roof wheel		7142002	9.9
			
750 Rolling roof wheel Adjustable	G	7142006	15.0
			
Anti-lift bracket Including bolt and nut		7175059	3.1
			
Triangular rail	2000 3000	7203332 7203333	31.7 44.0
			
Tripod	500 1000 2000 3000	7203340 7203341 7203342 7203343	10.0 17.3 31.8 45.8
			
Anti-lift channel Including bolt and nut	3000 2000	7175060 7175061	16.0 10.6
			
Band & plate coupler		2044100	2.2
			

Name	Code	Item No.	Weight
Straight track With Track joiner AL erected in upper end	1250 AL	7541125	2.6
	2250 AL	7541225	4.7
	3250 AL	7541325	6.7
	6250 AL	7541625	12.9
			
Ridge track Without erected Track joiner AL	15 AL	7541015	2.8
	22.5 AL	7541022	2.8
	37.5 AL	7541037	3.0
			
End track With Track joiner AL erected in upper end	15 AL	7541150	3.3
	22.5 AL	7541220	3.3
	37.5 AL	7541370	3.3
			
Fall protection anchor	15	7541007	10.4
	22.5	7541008	10.4
			
Track joint plate Track joiner Track seal	AL	7540000	0.2
		7540001	0.0
		7540002	0.0
			
Track clamp saddle Erected on framework 750 AL with 12 mm spring pin		7541000	0.5
			

Name	Code	Item No.	Weight
Track clamp end bracket Erected on framework 750 AL with 12 mm spring pin		7541002	1.3
			
Track clamp coupler		2048030	1.0
			
Ridge roller frame	1250 1655 2500 3050	7500018 7500019 7500020 7500021	11.2 13.9 17.9 20.5
			
Tension bar	1250 1655 2500 3050	7500013 7500027 7500014 7500015	5.9 7.6 10.6 12.9
			
Tension tube	1250 1655 2500 3050	7500024 7500028 7500023 7500022	4.3 5.9 9.2 11.3
			
Ratchet fixing strap		7540003	0.5
			

Name	Code	Item No.	Weight
Pulling device For sheeting	1250	7500011	7.8
	1655	7500025	9.4
	2500	7500009	12.6
	3050	7500008	14.8
			
Eaves roller bracket For sheeting		7500010	7.4
			
Guide Trak sheet For sheeting		7541005	1.1
			
HAKI Trak sheeting Produced to length and width as required 580 g/m ²		7542000	
			
HAKI Trak pelmet sheeting With keder beading on one side	1250	7542101	1.0
	2250	7542102	1.6
	3250	7542103	2.3
	6250	7542104	4.4
	ridge pelmet 15	7542105	1.0
	end pelmet 15	7542106	1.0
			

For other accessories, see HAKI Component List.

Information on safety when erecting and dismantling

1. Carry out local risk assessment and method statement.
2. Make sure that all lifting equipment to be used, e.g chain hoists, lifting ropes, pulley blocks, etc., has been thoroughly tested and approved by an authorised person in accordance with local regulations.
3. Check that tools and protective equipment are available at the worksite.
4. Wear appropriate personal safety equipment at all times, e.g. safety harnesses, proper independence lifelines with suitable fixings, etc.
5. When erecting and dismantling a scaffold, robust temporary decking must be used as temporary platforms for platforms for the scaffolders.
6. Always make sure that the safety locking devices that prevent a platform lifting off have been activated once a platform has been installed.
7. Study all relevant instructions or safety directions from the manufacturers of the various scaffolds that are to be used.
8. Never climb up a scaffold from the outside. Always use the stairs, ladders or climbing frames that are designed to provide access to the upper decks from the inside of the scaffold.
9. If the scaffold is to be used outdoors, erection or dismantling work must be discontinued if the weather conditions are too bad. Make sure that all loose components are properly fixed before leaving the scaffold.
10. Scaffolding work must be done by “competent operatives” under the supervision of a “competent person”.
11. Lifting equipment must not be attached to a free-standing scaffold.
12. Beware of any overhead power lines nearby.
13. Always observe and comply with the regulations issued by the local authorities concerned.

Instructions for dismantling

1. Dismantle the scaffold from the topmost lift.
2. Start by taking down the toe boards.
3. Take down the topmost decking.
4. Take down the horizontals and diagonals of the topmost lift.
5. Finally remove the standards where possible.
6. Repeat 2-6 to take down the second topmost lift and continue the whole process until the dismantling process reached the scaffold is completely dismantled.
7. Do not throw or drop materials to the ground. This may damage the material or cause personal injury. The materials must be lowered down to the ground by means of ropes or slings or passed down by hand.
8. If intermediate ties or tie rod tube have been installed, they must not be removed until the dismantling process reaches the level in question.
9. Always observe and comply with the regulations published by the local authorities concerned.
10. Reference should also be made to the section “Information on safety when erecting and dismantling” in this manual.

Fitting the roller track

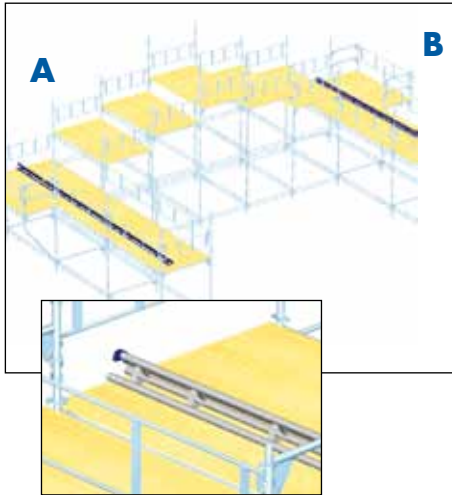

Side A

Fit the triangular rail, roller track, on the scaffolding with the U-section of the anti-lift device facing down and out with the couplers at positions specified by design drawing.

The triangular rail is joined in its two lower tubes using two 16 mm locking pins.

Ensure that the track is parallel to building structure.

Fit braking coupler to the end of the rolling track to prevent structure rolling back.

Side B

Fit a parallel roller track on the other side, but do not fully fix at this stage to allow alignment as erection progresses.

Fit braking coupler to the end of the rolling track to prevent structure rolling back.

Fitting the framework

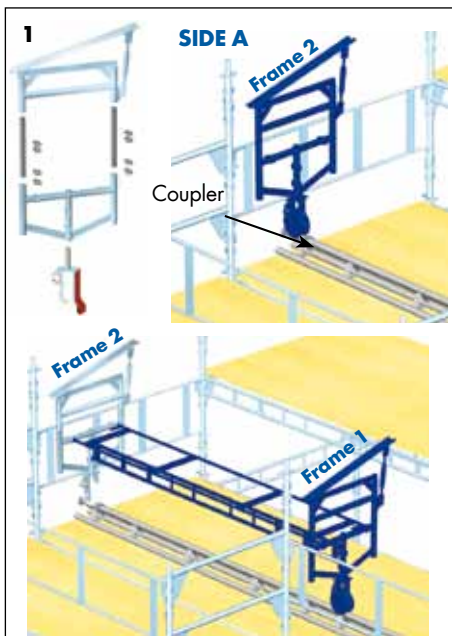

1. By frame 2, at the rear of the gable scaffold, place a rolling roof wheel with anti-lift device on the track.

Fit braking coupler immediately in front of wheel.

Fit a Y Frame on the wheel spigot and lock with a 16 mm spring pin.

Fit a beam adapter on the Y frame using two connector tubes and eight 12 mm spring pins.

If a frame is to be used on the sides of the roof, fit two connector tubes and eight 12 mm spring pins.

Level and temporarily fix the assembled parts to the rear of the gable scaffold.

Set the beam adapter to the correct angle. See page 25.

Repeat the above for frame 1 and join the Y frames together with a ledger beam and guardrail frame(s).

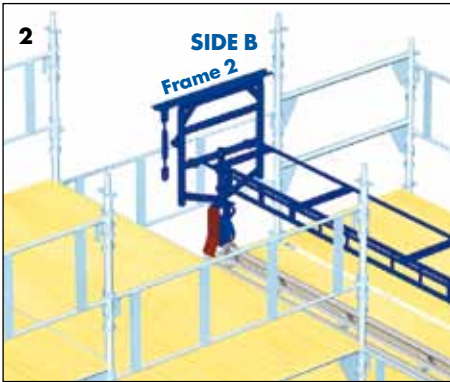

2. Repeat the above on side B.

For the beam adapter at side B, release the lower pin so that the top plate is lying horizontally.

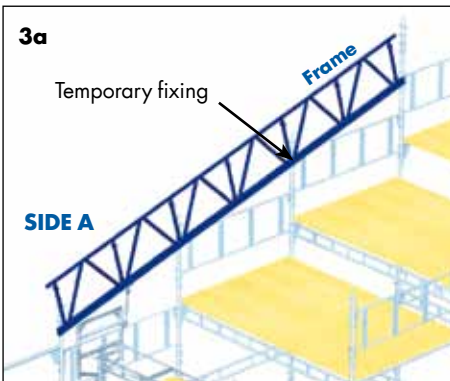

3a. Place the first frame on the beam adapter at the correct angle and fix temporarily to the rear of the gable scaffold.

Fit the remaining frames using two connector tubes and eight 12 mm spring pins at each joint.

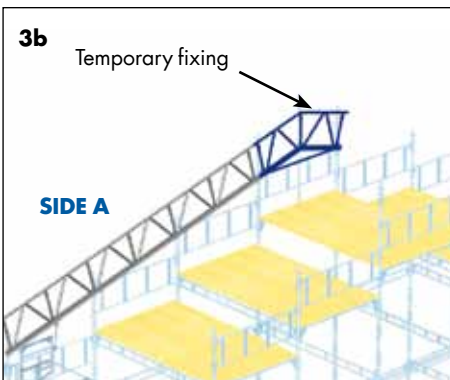

3b. Fit the angle frame using two connector tubes and eight 12 mm spring pins. Temporarily fix to the rear of the gable scaffold and level as required.

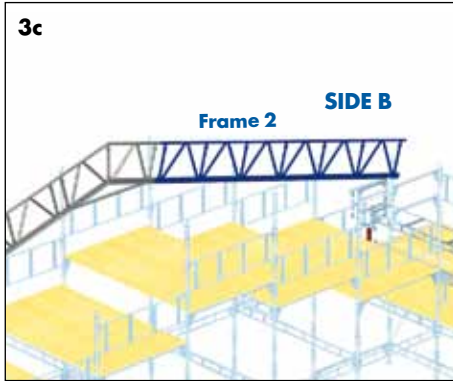

3c. Continue fitting the frames from the ridge to the eaves.

Remove all temporary fixings, except ridge.

For beam adaptor at side B, refit lower pin, adjust turnbuckle so that the top plate follows the contour of the beam.

Fit the clamping devices onto the beam adapters without fully tightening.

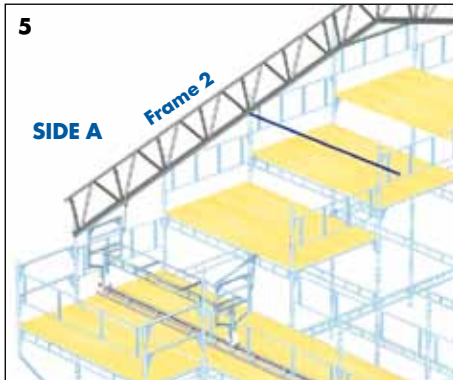

4. Loosen the temporary fixing in the ridge, without removing it and allow the complete truss to settle down and thus slide on the beam adapters.

5. To temporarily support the next truss at its settled shape, fix and level horizontal tubes to gable scaffold standards.

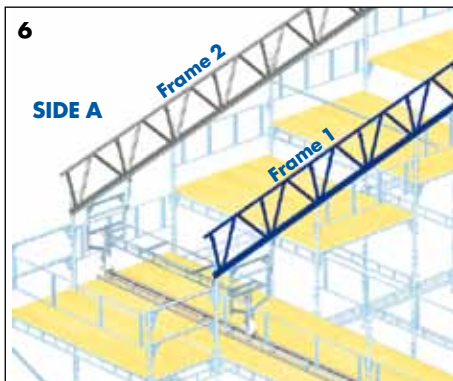

6. At the front edge of the gable scaffold, repeat step 3a with truss resting on temporary tubes as above.

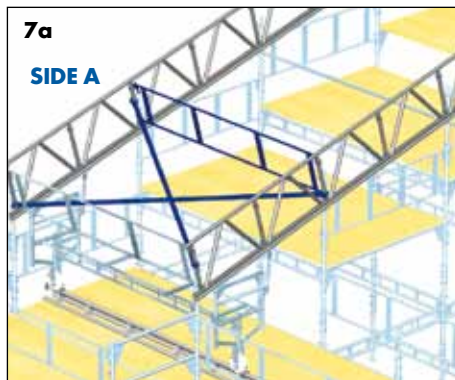

7. Fit a guardrail frame vertically in the outermost group of pockets in the eaves in order to obtain the correct distance between the lattice beams.

Fit the next guardrail frame 2 m from the first one and fit two crossing plan braces into this bay. These will ensure that the bay is square.

One of these plan braces can be removed later.

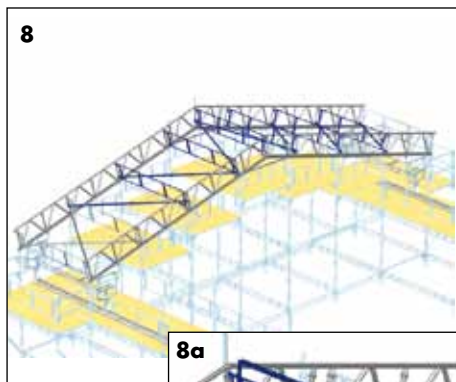

8. Work from one side to the other and fit the remaining lattice beams, guardrail frames and plan braces until the frame up to the first bay is finished.

A ridge roller frame is fitted in the ridge. See figure 8a.



9

9. Slide the track clamps into the HAKI Trak tracks and tighten the nuts with fingers.

Ridge track = 2 track clamps

Track 1.25 m = 2 track clamps

Track 2.25 m = 3 track clamps

Track 3.25 m = 4 track clamps

Track 6.25 m = 7 track clamps

End track = 1 track clamp

Fit the HAKI Trak ridge track centred on the angle frame and secure with 12 mm spring pins. Tighten the nuts with a 22 mm spanner.

If pelmet sheet is to be used, insert the ridge pelmet.

Prepare the next HAKI Trak track by adding the track joiner, seal and track joint plate.

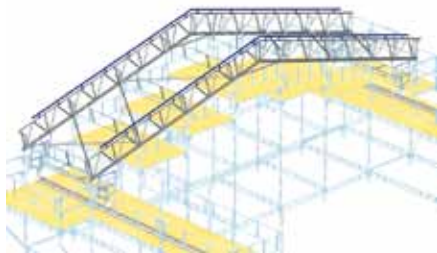
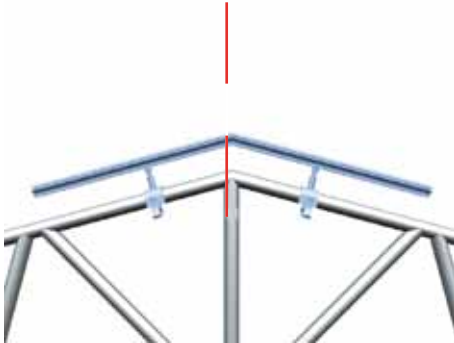

Work downwards towards eaves and fit the remaining HAKI Trak tracks and pelmet sheets.

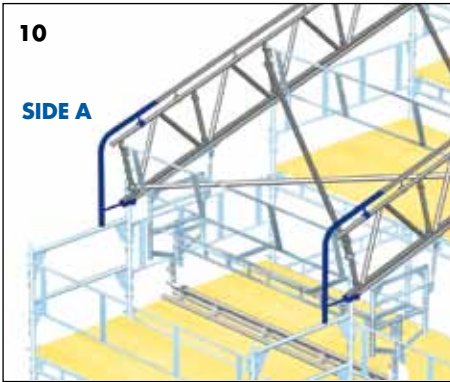

10. At eaves fit HAKI Trak end tracks and the track clamp end brackets using 12 mm spring pins.

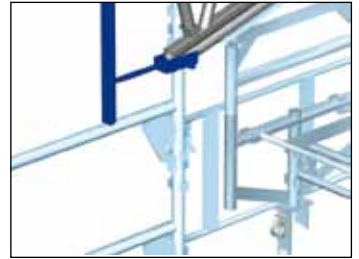

11. One of the crossing plan braces in first bay can now be removed.

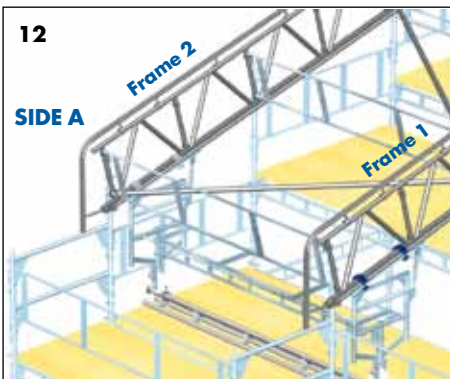

12. On frame 1, tension the clamping devices on the beam adapters properly before rolling out.

On frame 2 the clamping devices should be loosely tightened until section 2 is in place.

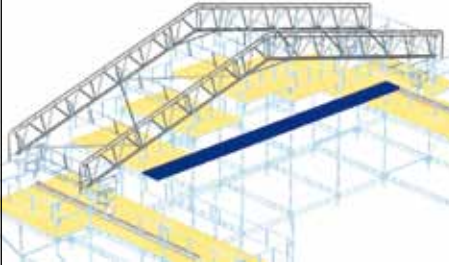
12A

If the design requires knee braces, tie chords etc., a cantilevered platform is provided at an appropriate level throughout the whole gable length.

Knee braces, tie chords, droppers etc may be safely erected from this platform.

Remember, always attach lanyard to aluminium beam, when not protected by guard rail.

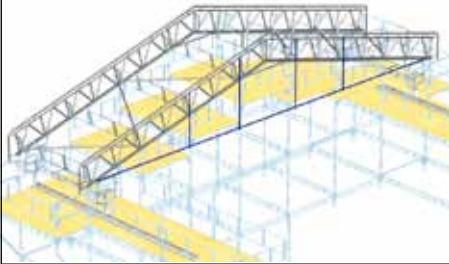
13

13. Fully fix first unit of rolling track on side B.

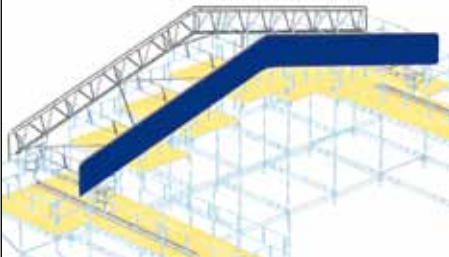
14

14. Where applicable, check that the pelmet sheet is fitted on frame 1. See page 22.

The bay is now ready for sheeting.

NOTE:

Check that the wind conditions are not too excessive during the sheeting and rolling out.

The anti-lift bracket will not necessarily restrain the roof for full design wind loading. Check with the design documents!

Sheeting

NOTE:

Prior to sheeting, ensure that any additional equipment to comply with the design documents is installed, e.g. knee-braces, ties, anchors, counter-weights etc.

Sheeting from bays at side scaffolds



15. Fit pair of eaves roller brackets on the outermost guardrail frame at each side of roof.

Place two ropes of sufficient length from side to side over the complete bay of roof.

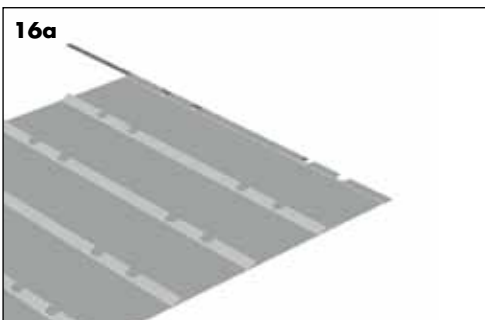

16. Position sheet on one side A.

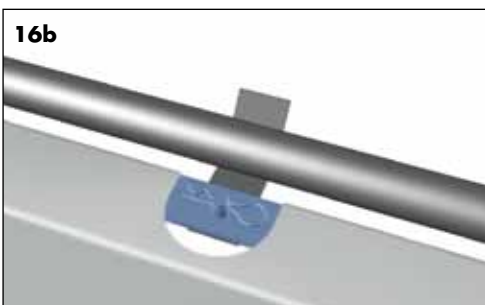

Thread sheeting bar through sheet pocket and attach to pulling device.

Attach ropes to pulling device and take up slack from the opposite side B.

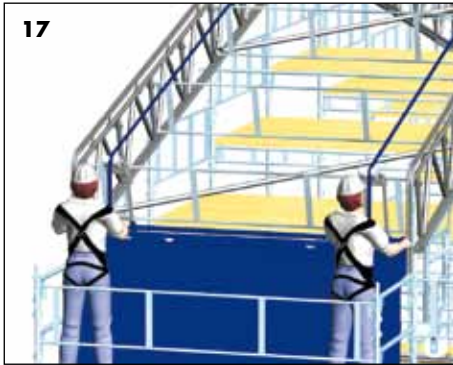

17. Carefully pull in the ropes. Make sure that the pulling device wheels are correctly positioned and feed end of sheet into open end of track.

17b. To make it easier to feed in the HAKI Trak sheeting into the tracks, erect first the guide trak sheet in each track.

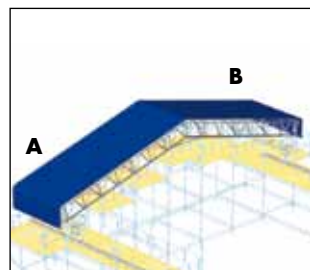
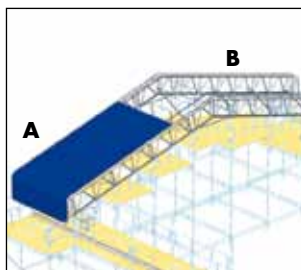
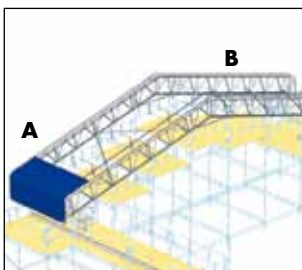
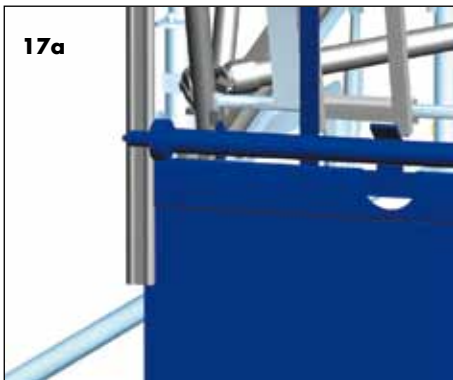

Continue to pull over the sheet until 100 to 300 mm of the sheet remains outside the HAKI Trak tracks on side A.

Remove the eaves roller brackets from both sides.

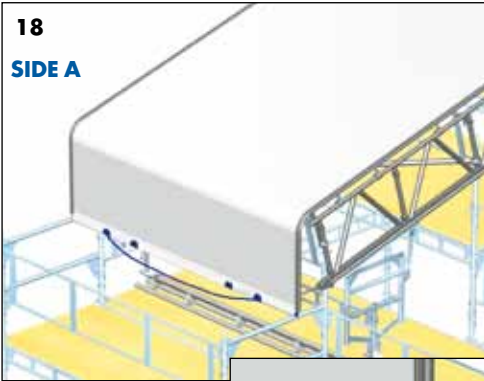

18. On side A, push the tension bar through the sheet pocket.

Pull in the sheet so that the tension bar's pins fit into the ends of the HAKI Trak tracks.

Fit the ratchet fixing straps between the loops on the tension bar to retain inside sheet pocket.

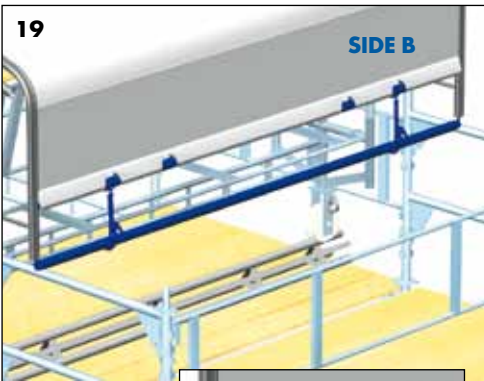
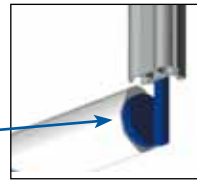
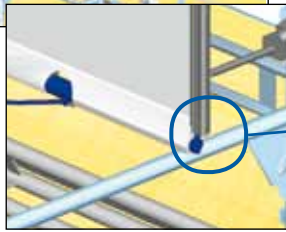

19. On side B, remove pulling device and sheeting bar.

Thread tension tube through sheet pocket.

Fit ratchet straps around tension tube and tension bar located through loops.

Locate tension bar in end of HAKI Trak.

Tension the sheet using ratchet fixing straps between the tubes.

It is important that the sheet is fully tensioned.



Rolling out

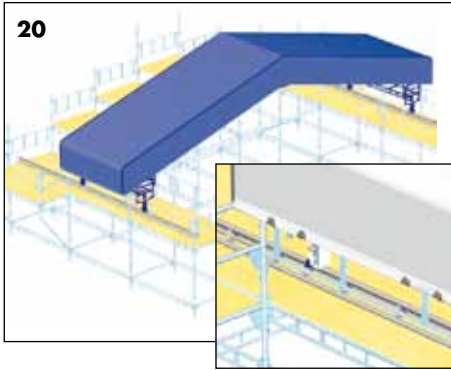

20. Release temporary fixings at trusses and rolling gear. Move braking couplers forward along track.

Roll entire roof structure such that frame 2 is then positioned at front edge of gable scaffold.

Fit brake couplers to rolling track to prevent structure rolling further than required distance.

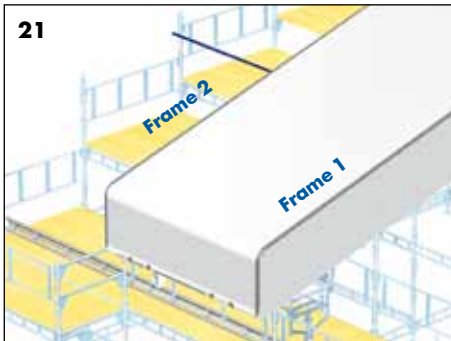

21. Fix level horizontal tubes to gable scaffold standards at the underside of frame 2. These will act as a template for subsequent trusses.

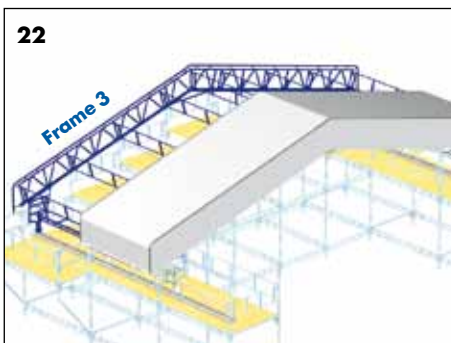

22. Repeat steps 6 to 19 for the rest of the roof structure. Only install additional plan bracing as required by the design drawing.

The clamping devices on the beam adapters on frame 2 are to be tensioned properly before rolling out.

If the design documents specify any additional means of tying down, these must be carried out before starting further assembly. This also applies if the uncompleted structure is left overnight etc.

REMOVING ROLLING EQUIPMENT

For this procedure, it is essential that **ADJUSTABLE ROLLING ROOF WHEELS** are used

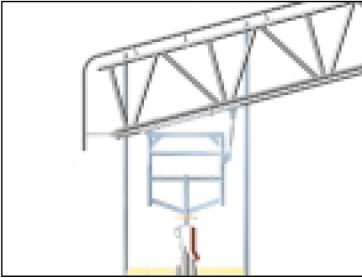

As per design drawing, fix Standards to side scaffold to correspond with truss positions.

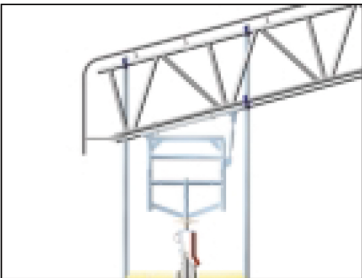

Fix trusses to standards using method specified by the design drawing.

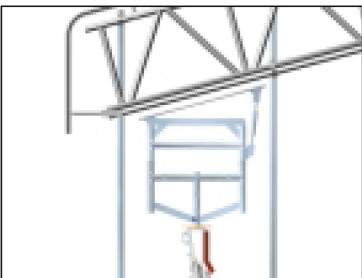

Remove Pin & Chain from Rolling Roof Wheel.

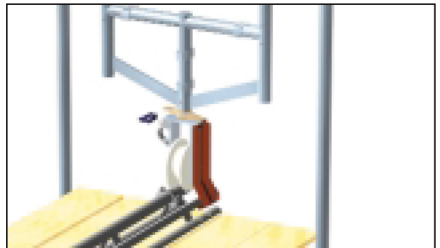

Remove adaptor clamps and wind down the wheel jacks until the beam adaptor is fully clear of the underside of the truss.

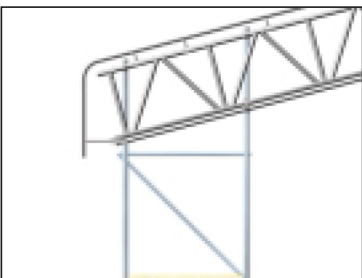

The rolling gear can then be moved away from the underside of the truss. Dismantle and remove. Fit specified Lacing and Bracing.

Access arrangements for temporary roofs

Access to a temporary roof may be achieved via erection scaffolding, special access stairways or special access brackets.

PLEASE NOTE: You must be able to anchor yourself at the point of ascent and then be anchored during your entire stay on the roof. You can do this by having an extra rope that is used while you are moving from the point of ascent to the attachment eyes or wire on the ridge of the roof.



HAKI Fall protection Anchor

Personal fall protection equipment can be anchored to HAKI fall protection anchors or to wires fitted to the ridge between HAKI fall protection anchors.

HAKI fall protection anchors are fitted to HAKI 750 AL angle frames in connection with the erection of the temporary roof.

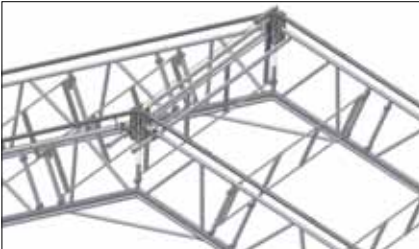

The fall protection anchor in place

The HAKI Fall Protection Anchor is designed for the HAKITEC 750 temporary roof with the HAKI Trak.

The Fall Protection Anchor should be fitted to the HAKI 750 AL angle frame 15°, item no. 4202260 or 22.5° item no. 4202261 and should be used as anchor points for an approved CE marked fall protection system of the horizontal steel wire system type such as Xenon, Safe line.

Maximum tension of 13 kN in the wire when fitting according to the diagram and with two struts of Ø48 scaffold tube with RA 48x48 fixed connections fitted to the outer frame.

When fitting, check that the fall protection system's screws and nuts are tightened with the required torque, 120 N.m for an M14 screw and 80 N.m for an M12 screw.

The greatest recommended distance between fall protection anchors is 15 m.

See HAKI product sheet for further information.

See the fall protection system's manual for permissible loading and span.



Exploded diagram



The fall protection anchor with ridge track

Personal fall protection equipment

Working on temporary roof is associated with a risk of falling. Everyone on a temporary roof must, therefore, use personal fall protection equipment, which means a full-body harness, lifeline, shock absorbing fall arrest lanyard, and rope adjuster or retractable block.

PLEASE NOTE: Do not use a safety belt when working on a roof.

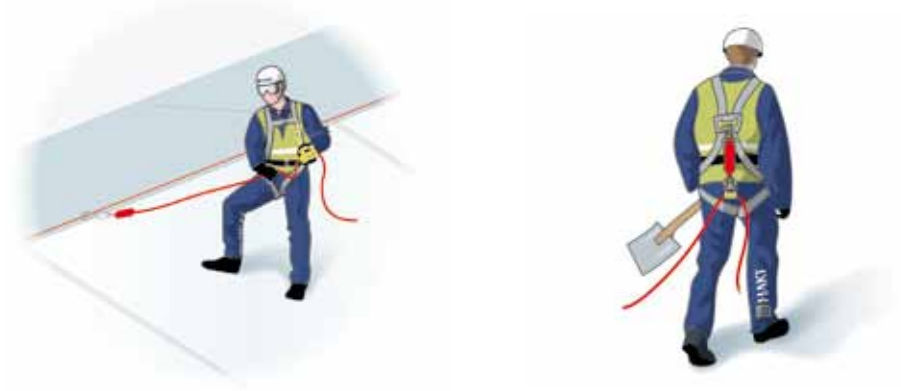

PLEASE NOTE: It is important to attend a training course in the use of personal fall protection equipment before using it in practice.

Anchorage of personal fall protection equipment

Anchored using a harness and rope, you should be able to reach all parts of the roof with the rope at a maximum oblique angle of 15° to the normal.

Please note the pendulum risk at fall!

It may sometimes be necessary to anchor yourself using two ropes to two different places in order to be able to work safely at the extreme corners of the eaves. Where required, fit extra fall protection anchors.

The wire can usually be ended a short distance from the gable of a normal saddle roof.

See HAKI product sheet for further information.

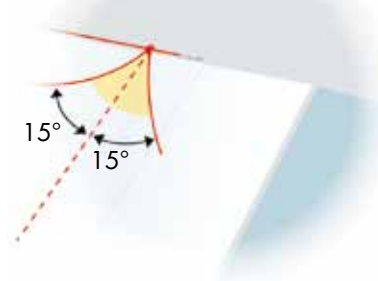

Safely clearing snow from temporary roofs

The work of clearing snow from a roof must be done by a well-coordinated team with at least two skilled people on the roof and at least one standing guard on the ground. It is also very important that personnel with extensive experience of working on roofs be in charge of this work.

The roof must also be correctly provided with access and anchorage devices for personal fall protection equipment.

PLEASE NOTE: Sharp objects and careless handling can easily damage the roof sheeting. Make sure, therefore, that you use snow shovels and other equipment that is suitable for the temporary roof. It is better to leave a few centimetres of snow or ice than to risk damaging the roof.

In order to protect people and property, it is important to cordon off the risk area on the ground below the roof and to have the area guarded by someone who has constant contact with the people clearing the snow on the roof.

Clear both halves of the roof evenly in order to avoid uneven loading of the roof by too much snow. Draw up a snow clearance plan in consultation with the designer of the roof.

See also Work Environment brochure “ Safer shoveling”.

Maintenance & storage

1. After use, all components must be thoroughly cleaned and inspected before storage.
2. Any damaged parts or components found must be replaced.
3. The manufacturer or supplier must be consulted before repairing scaffold material.
4. Components must be sorted and stacked properly. Take care not to pile the stacks too high, so that the material lower down in the stacks becomes overloaded and damaged. If the material must be stacked up high, suitable racking and shelves should be used.
5. Wooden and plastic components (e.g. platforms, toe boards, toe board holders, etc.) should be stored in a sheltered area so as to maximize their working life.

Sheet information

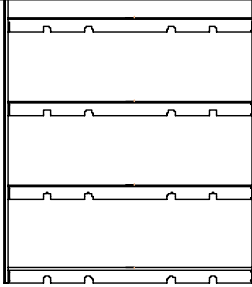
	<p>HAKI Trak sheeting</p> <p>Base material: Polyester Coating: Flexible PVC on both sides Weight: 580 g/m² Temperature resistance: -20°C Flame retardant to BS.5438 2A (No flame or after glow)</p>
---	--

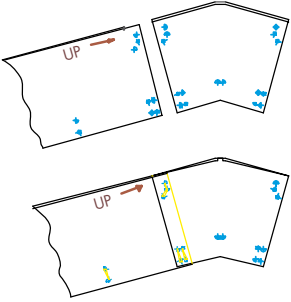
<p>HAKI Trak pelmet sheeting</p> <p>Fit the ridge pelmet and fix it vertically to the angle frame using cable ties or similar.</p> <p>Slide next full pelmet sheet with cut-out edge uppermost.</p> <p>Mate pelmets together so that overlapping flap is downward. Fix through common eyelets using cable ties or similar. Repeat for all pelmet sheets along side of gable.</p>	
---	---

Technical information

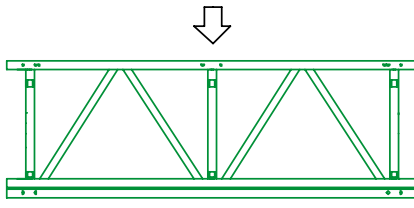
<p>HAKI Frame 750</p> <p>To be braced with guardrail frames at least every other metre.</p> <p>Average weight = 7.5 kg/m</p> <p>Permitted bending moment = 41.3 kNm</p> <p>Permitted shearing force = 30 kN</p>	
--	--

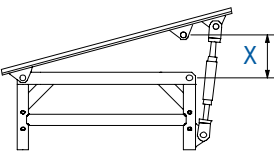
	<p>Beam adapter 750</p> <p>for 15° X = 180 mm for 22.5° X = 255 mm</p>
--	--

<p>HAKI Trak track</p> <p>Weight=2.1 kg/m</p>	
--	---

CHECKLIST - Check before erection

1. Are the design documents on site?
2. Has the supporting scaffold been erected in accordance with the design documents and is it ready to receive the roof structure?
3. Is the correct equipment on site?
4. Is the equipment in good working order?
5. Are the right tools on site?
6. Is the appropriate safety equipment on site?
 - Safety harness with fixed length double lanyard
 - Rescue procedure
7. Has the following been taken account in the planning?
 - the number of scaffold erectors
 - designated tasks
 - starting position for erection
 - distribution of equipment

