

USER'S MANUAL HAKI UNIVERSAL S4 ALUMINIUM

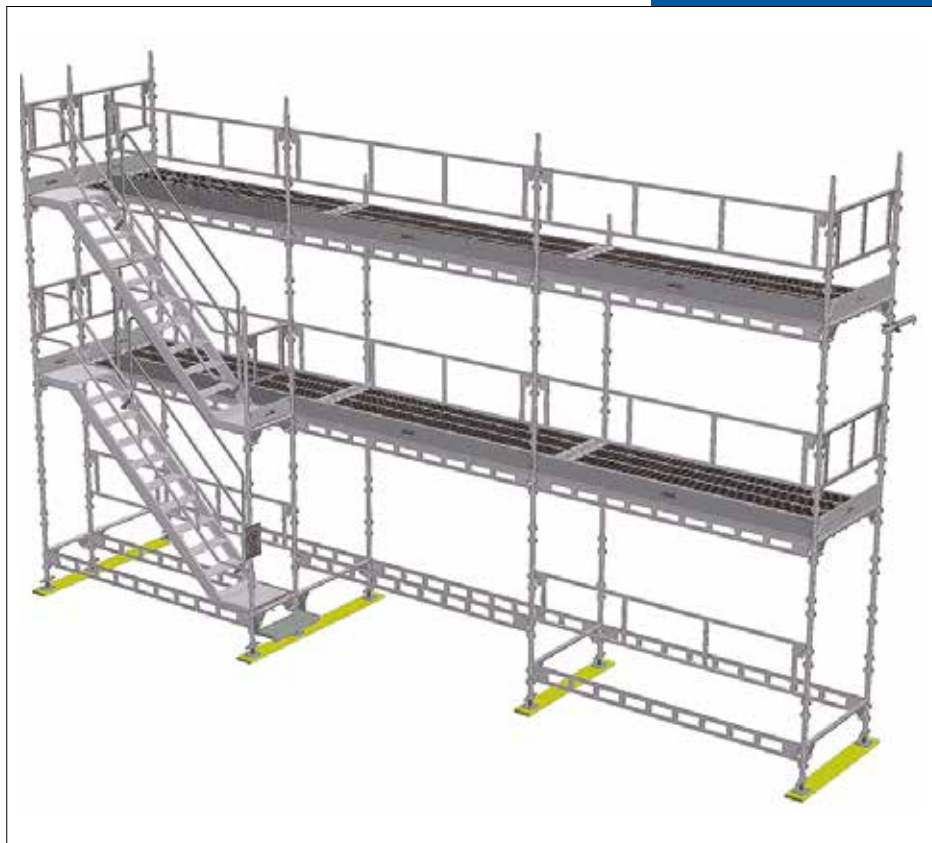

Important information

HAKI's product liability and user's manuals apply only to scaffolds that are entirely composed of components that have been made and supplied by HAKI.

HAKI's type examination certificate applies only to scaffolds whose materials, dimensions and design accord with those specified in the documentation upon which this certificate is based.

HAKI's scaffold systems must not be erected using components of makes other than HAKI or be connected to scaffolds of makes other than HAKI. In such cases, a special study of load-bearing capacity must be carried out. However, HAKI has no objection to the customary addition of scaffold tubes and approved couplers to the scaffold.

Adding components from different suppliers may invalidate the insurance cover.

HAKI reserves the right to make technical modifications on a continual basis.

This user's manual is to be used in conjunction with HAKI training courses.















A user's manual should be provided to the user together with the scaffolding.

The latest versions of HAKI user's manuals can be downloaded from our website, www.HAKI.com.

For scaffold structures that are not covered by this user's manual, please contact HAKI's technical department.

HAKI colour code

Horizontals and diagonals are marked with their nominal sizes (bay sizes) and a colour code. The marking is a useful means of identification when erecting and handling the scaffold material.

564 	1050 	1964 	3050 
700 	1250 	2050 	*3650 
770 	1550 	2500 	*4050 
1010 	1655 	2550 	* non-stock length

Forces and dimensions

1000 N = 1 kN ~ 100 kg

10 N ~ 1 kg

All measurements in mm

© Copyright HAKI AB, 2019

The reproduction of text and pictures/illustrations without HAKI's permission is prohibited.

HAKI Universal Aluminium S4

PLEASE NOTE: This user's manual applies solely to scaffolding erected using only HAKI's S4 AL standards.

Permitted loads on standards and thus construction heights apply solely to HAKI's S4 AL standards.

HAKI's S6 AL standards must not be incorporated into the scaffolding structure. HAKI's S6 AL standard has a wall thickness of 6 mm and a spigot of \varnothing 34 mm, which means that it is incompatible.

On the other hand, HAKI's older FSSH AL standards, with welded pockets, may be incorporated into the scaffolding structure, but lower permitted loads on standards then apply in accordance with the user's manual for this system.

In addition, HAKI Universal steel standards may be used, for example in the base of the scaffolding when loads on standards are high or when construction heights are great. In such cases, a special study of the bearing capacity must be carried out.

However, HAKI's other products, including horizontal members, decking etc. of steel or aluminium, may be fully employed in the scaffolding system.



How to identify HAKI's S4 standard

- Plain spigot centred using eight indentations and fixed using a strong aluminium through rivet.
- The wall thickness of the standard tubing is 4 mm.
- Rings of pockets are attached to the standard tube using a special riveting technique.
- HAKI label with white background and the word HAKI in blue.



HAKI Universal Aluminium

The modular scaffold has been type examined by RISE Research Institutes of Sweden in accordance with Ordinance AFS 2013:4 of the Swedish National Board of Occupational Safety and Health Code of Statutes and SS-EN 12810 and 12811 – Certificate no. 14 55 17 – for load class 1-5 (0,75-4,5 kN/m²).









General data

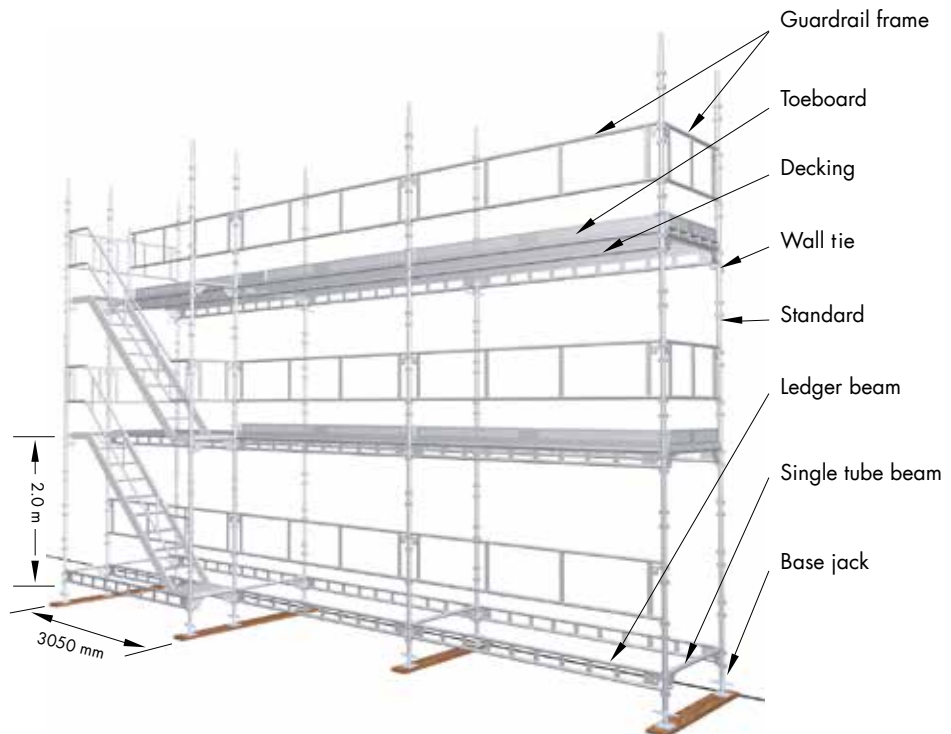





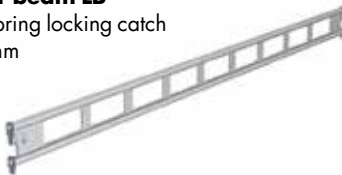

HAKI Universal Aluminium is erected with bay widths of 700, 770, 1050, 1250 or 1655 mm and normally with a bay length of 3050 mm and 2.0 m between lifts. LB or ERB beams can be used both as ledger and transom beams. HAKI decking unit light or AL planks are suitable for decking.





Marking





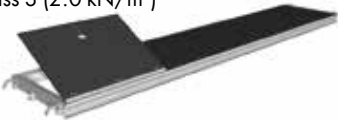

All components with the exception of locking catches, locking pins etc. come permanently marked with the HAKI logo and the last two figures of the year of manufacture (■ S19).



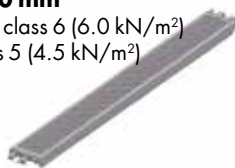
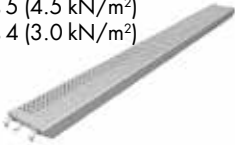
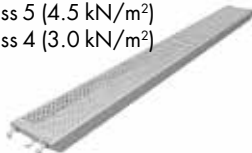







Name		Code	Item No.	Weight
Base jack Steel Ø 38 mm Adjustable 55-570 mm		BS	2071000	5.0
Standard S4 AL Standard joint with spigot Ø 38 mm Pockets at same level Ø 48 mm		S4 500 S4 1000 S4 1500 S4 2000 S4 3000	4017056 4017106 4017156 4017206 4017306	1.6 2.8 4.0 5.2 7.7
Locking pin Steel Ø 16 mm			5141257	0.3
For reinforcing standard joint in connection with tensile load, e.g. when scaffolding is suspended, when lifting or when scaffolding is used for temporary roof.			2116000	0.2
Ledger beam LB With spring locking catch Ø 34 mm		LB 350 AL LB 770 AL LB 1050 AL LB 1250 AL LB 1655 AL LB 1964 AL LB 2500 AL LB 3050 AL	4021031 4021073 4021101 4021121 4021161 4021191 4021246 4021301	1.9 2.9 3.5 4.2 4.8 5.8 7.2 8.5
Single tube beam ERB With spring locking catch Ø 48 mm		ERB 564 AL ERB 700 AL ERB 770 AL ERB 1050 AL ERB 1250 AL ERB 1655 AL ERB 1964 AL ERB 2500 AL ERB 3050 AL	4022051 4022066 4022073 4022101 4022121 4022161 4022191 4022246 4022301	2.5 2.7 2.9 3.2 3.6 4.1 4.5 5.4 6.2

Name	Code	Item No.	Weight
Guardrail frame SKRD With spring locking catch 	SKRD 700 AL	4052066	3.3
	SKRD 770 AL	4052073	3.5
	SKRD 1050 AL	4052101	4.5
	SKRD 1250 AL	4052121	4.8
	SKRD 1655 AL	4052161	5.9
	SKRD 1964 AL	4052191	6.6
	SKRD 2500 AL	4052246	7.8
	SKRD 3050 AL	4052301	8.9
Diagonalbrace 	DS 1250 AL	4122120	4.5
	DS 1655 AL	4122160	4.9
	DS 1964 AL	4122190	5.4
	DS 2500 AL	4122245	6.1
	DS 3050 AL	4122300	6.7
Plane brace 	HDS 3050x1655 AL	4141000	7.0
	HDS 3050x1250 AL	4141001	6.5
	HDS 2500x1250 AL	4141005	6.0
	HDS 2500x1655 AL	4141006	6.3
Plan brace telescopic 	HDS AL	4141010	6.3
Wall tie With flexible plate Ø 48 mm Erected with right angle coupler 48x48 	VST 1000	7111100	5.3
	VST 2000	7111200	9.1
	VST 3000	7111300	13.7
	VST 4000	7111400	16.7
	VST 5000	7111500	21.9
	VST 6000	7111600	24.5
Tie rod tube AL Tube diameter 48 mm Permissible load 5.4 kN Erected with coupler 48x48 	SVF 450x48 AL	4832045	1.2
Tie rod tube Ø 48 mm Permissible load 9 kN Erected with right angle coupler 48x48 	SVF 450X48	8832046	2.2
	SVF 600x48	8832061	2.6
	SVF 900X48	8832091	3.7
	SVF 1200X48	8832121	4.8
Decking unit light W=400 mm Load class 3 (2.0 kN/m ²) 	1050x400	4073102	7.1
	1250x400	4073122	8.5
	1550x400	4073152	10.0
	1655x400	4073162	10.5
	1964x400	4073192	12.0
	2050x400	4073202	12.4
	2500x400	4073252	15.1
	2550x400	4073257	16.5
3050x400	4073302	18.5	

Name	Code	Item No.	Weight
Decking unit light W=600 mm Load class 3 (2.0 kN/m ²) 	700x600	4071072	6.6
	1050x600	4071102	9.1
	1250x600	4071122	10.6
	1550x600	4071152	12.8
	1655x600	4071162	13.5
	1964x600	4071192	15.8
	2050x600	4071202	16.4
	2500x600	4071252	19.6
	2550x600	4071257	20.0
3050x600	4071302	24.6	
Decking unit light hatch Load class 3 (2.0 kN/m ²) 	2500x600 AL	4071253	19.5
	3050x600 AL	4071305	24.5
Ladder For decking unit with hatch 	ST 2100 AL	2091210	3.4
Decking unit light hatch and ladder Load class 3 (2.0 kN/m ²) 	3050x600 AL	4071306	25.0
AL plank W=200 mm L=770-2500 - Load class 6 (6.0 kN/m ²) L=3050 - Load class 5 (4.5 kN/m ²) 	ALP 770x200x90	2153079	3.6
	ALP 1050x200x90	2153105	4.5
	ALP 1250x200x90	2153125	5.0
	ALP 1655x200x90	2153165	6.2
	ALP 1964x200x90	2153195	7.1
	ALP 2500x200x90	2153255	8.7
	ALP 3050x200x90	2153305	10.3

Name	Code	Item No.	Weight
AL plank W=230 mm L=770-2500 - Load class 6 (6.0 kN/m ²) L=3050 - Load class 5 (4.5 kN/m ²)		ALP 770x230x90	2158077 4.1
		ALP 1050x230x90	2158100 4.9
		ALP 1250x230x90	2158120 5.6
		ALP 1655x230x90	2158160 6.8
		ALP 1964x230x90	2158190 7.8
		ALP 2500x230x90	2158245 9.5
		ALP 3050x230x90	2158300 11.2
AL plank W=295 mm L=770-1964 - load class 6 (6.0 kN/m ²) L=2500 - load class 5 (4.5 kN/m ²) L=3050 - load class 4 (3.0 kN/m ²)		ALP 770x295x90	2153078 4.4
		ALP 1050x295x90	2153104 5.5
		ALP 1250x295x90	2153124 6.1
		ALP 1655x295x90	2153164 7.5
		ALP 1964x295x90	2153194 8.6
		ALP 2500x295x90	2153254 10.5
		ALP 3050x295x90	2153304 12.4
AL plank W=320 mm L=770-1964 - load class 6 (6.0 kN/m ²) L=2500 - load class 5 (4.5 kN/m ²) L=3050 - load class 4 (3.0 kN/m ²)		ALP 770x320x90	2153077 4.6
		ALP 1050x320x90	2153103 5.7
		ALP 1250x320x90	2153123 6.4
		ALP 1655x320x90	2153163 7.9
		ALP 1964x320x90	2153193 9.0
		ALP 2500x320x90	2153253 11.0
		ALP 3050x320x90	2153303 13.1
Toe board AL		Toe board 564 AL	4161051 1.0
		Toe board 700 AL	4161071 1.3
		Toe board 1050 AL	4161105 1.9
		Toe board 1250 AL	4161121 2.2
		Toe board 1655 AL	4161161 2.9
		Toe board 1964 AL	4161191 3.5
		Toe board 2500 AL	4161251 4.6
		Toe board 3050 AL	4161301 5.5
Toe board Wood		FL 3300x150x32	2025331 6.7
Toe board clip Steel		LF 70	7161006 1.0
Bracket Without spigot With spring locking catch Ø 48 mm		SK 230 AL	4211024 1.7
		SK 460 AL	4211047 1.9
Bracket with spigot With spigot Ø 38 mm With spring locking catch		SK 564 AL	4211052 3.6
		SK 770 AL	4211074 3.9

Name	Code	Item No.	Weight
Bracket With spigot Ø 38 mm With spring locking catch 	SK 1250 AL	4211121	11.0
Stair 	UTV 3050x2000 AL UTV 2500x2000 AL	4102302 4102247	29.2 22.9
Stair handrail 	HL 3050x2000 AL HL 2500x2000 AL	4058300 4058245	10.3 9.2
Handrail inner UTV AL G 	HL inner UTV AL	7058253	11.4
Guardrail post Steel For erection on ledger beam LB 	SRS 1000	7015001	7.3
Guardrail post Steel Jaw width 23 mm or 22 mm For erection on single tube beam ERB 	SSKS 23 mm SSKS 22 mm	7015005 7015006	6.1 6.1
Lattice beam 450 AL with pockets 	FB 2220 AL FB 4100 AL FB 6100 AL FB 8100 AL	4032211 4032411 4032611 4032811	9.9 17.8 25.8 34.0
Lattice beam 450 AL 	FB 4100 AL FB 6100 AL FB 8100 AL	4032410 4032610 4032810	16.7 24.3 32.2

For other accessories, see HAKI Component list.

Information on safety when erecting and dismantling

1. Before erecting or dismantling a scaffold, try to fence off the working area if possible.
2. The location for the scaffold must be checked in order to prevent risks when erecting, dismantling and moving the scaffold and to ensure that work can be carried out safely with regard to level and slope, obstacles and wind conditions.
3. Make sure that all lifting equipment to be used, e.g. chain hoists, lifting ropes, pulley blocks, etc., has been thoroughly tested and approved by an authorized person in accordance with local regulations.
4. Check that tools and protective equipment are available at the worksite.
5. Wear appropriate personal safety equipment at all times, e.g. safety harnesses, proper independent lifelines with suitable fixings, etc.
6. When erecting and dismantling a scaffold, robust temporary decking must be used as temporary platforms for the scaffolders.
7. Always make sure that the safety locking devices that prevent a platform lifting off have been activated once a platform has been installed.
8. Study all relevant instructions or safety directions from the manufacturers of the various scaffolds that are to be used.
9. Never climb up a scaffold from the outside. Always use the stairs, ladders or climbing frames that are designed to provide access to the upper decks from the inside of the scaffold.
10. If the scaffold is to be used outdoors, erection or dismantling work must be discontinued if the weather conditions are too bad. Make sure that all loose components are properly fixed before leaving the scaffold.
11. Scaffolding work must be done by “competent workmen” under the supervision of a “competent person”.
12. Raising and lowering of parts, material and tools using ropes or slings must be carried out in a protected lifting area.
13. Lifting equipment must not be fitted to scaffolding unless ties or equivalent devices are secure.
14. Beware of any overhead power lines nearby.
15. Always observe and comply with the regulations issued by the local authorities concerned.

Instructions for dismantling

1. Dismantle the scaffold from the topmost lift.
2. Start by taking down the toe boards, mid-rails and hand rails.
3. Take down the topmost decking, then the stairs.
4. Take down the horizontals and diagonals of the topmost lift.
5. Finally, take down the standards of the topmost lift.
6. Repeat steps 3 to 5 to take down the second topmost lift and continue the whole process until the tower is completely dismantled.
7. Do not throw or dump the material onto the ground. This may damage the material or cause personal injury. The material must be lowered down to the ground by means of ropes or slings or carried down by hand.
8. Ties must not be removed before the dismantling process has reached the level in question.

Before erecting the scaffold, check and flatten out the ground. The support surface must not be subject to uneven settlement. Its bearing capacity may be improved with the help of mud sills.



1.

1. Set out the material for the base and the first lift along the facade.

Place the base jacks about 200 mm out from the facade and at the modular distances that are to be used.

If inside brackets are to be used, increase the distance accordingly.

The greatest permissible distance between wall and work platform is 300 mm.

Always start erection at the point that is situated highest.



2.

2. Erect the first four standards, linking them with the transom and ledger beams.

The beams are fitted to the lowest group of pockets on the standards.

Check that the beam locks are in the locked position after fitting.

3. Fit the SKRD guardrail frames along the scaffold at a level of 1.0 m.

Guardrail frames must be fitted in each bay and at each lift level on the outside of the scaffold.

Alternatively, fit the vertical diagonal braces.

Continue erecting the base of the scaffold bay by bay using base jacks, standards, transoms and ledger beams and guardrail frames.

If HAKI UTV stairways are to be used, plan a 2500 or a 3050 mm bay for the ascent.

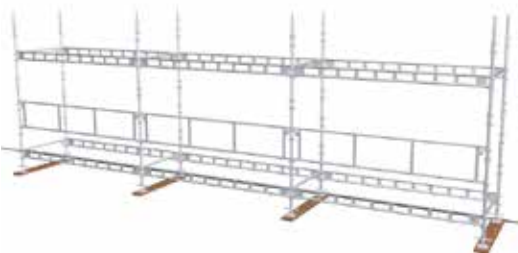

3.

From time to time, check the levels in both the transverse and longitudinal directions using a spirit level and adjust using the swivel base jacks.

If there are major differences in levels, adjust each individual standard in relation to the support surface so as to make the beams level.



4.

4. Fit the transom and ledger beams for the second lift 2.0 m above the beams that were fitted first.

Fit HAKI decking units to the transom beams. Don't forget to lock the decking.

Fit the second set of 3000 or 2000 mm standards.

Install SKRD guardrail frames for the second lift and fit the toeboards.

Don't forget the end guardrails.

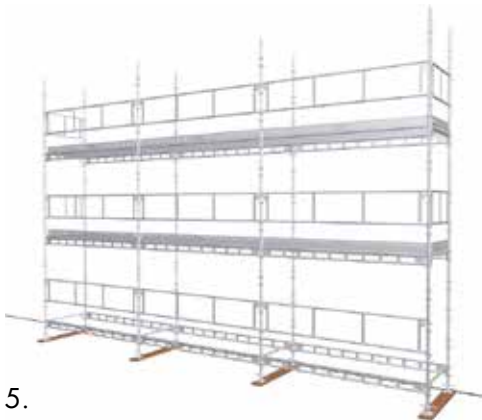

5.

5. Fit the transom and ledger beams for the third lift and then decking, guardrails and toeboards. Don't forget to lock the beams and decking.

Anchor the scaffold at a height of approximately 4.8 m using tie rods and clamps.

Check that the fixings in the facade can carry the forces involved.



6.

6. Continue erecting the subsequent lifts as described above.

Use approved lifting aids for transport of the material.

If steel/aluminium planks are used, these should be locked in the outer bays. The planks otherwise lock each other.

When decking using scaffold boards, these must be provided with yokes if the span exceeds 2.5 m.

Dismantling is done in the reverse order.

Scaffolding material must not be thrown down from the scaffold.

External stairways

There are two options for external stairways: the HAKI UTV of steel and the HAKI UTV of aluminium. Both options are fitted in a similar manner.



7. The UTV stairway is fitted in an external bay using ERB 700/770 and LB/ERB 2500/3050 beams. The stairway is usually built into the scaffold proper. Alternatively, the stair tower is erected using separate standards.

Set out the base jacks and erect the standards. Fit the ERB 700/770 and LB/ERB 2500/3050 beams into the lowest group of pockets. Fit the transom beams for the second lift too. At other levels, the handrails replace the ledger beams.



8. Fit the hooks of the UTV stairway over the tubes of the transom beams and lock the stairs using the locking device.

Fit the handrail at the 1.0 m level and provide the top end with SKRD 700/770 guardrail frames. Fit the next set of standards, transom beams, stairs, handrail and guardrail frames.



9. Continue erection up to the desired height.

At the top level, an ERB 2500/3050 beam is fitted externally in the scaffold. An SSK 1000 guardrail post is fitted on the beam so that an SKRD 1964/2500 guardrail frame can be fitted between post and standard. Alternatively, an LB 2500/3050 beam can be combined with an SRS 1000 guardrail post.

The guardrail frame provides fall protection at the top level of the scaffold. At other levels, the next stairway provides sufficient protection.

Load classes

Refers to EN 1281 1-1

Load class	Uniformly distributed load [kN/m ²]	Concentrated load on area 0.5m x 0.5m [kN]	Load of one person on area 0.2m x 0.2m [kN]	Partial area load	
				Load [kN/m ²]	Partial area [m ²]
1	0.75	1.5	1.0	-	-
2	1.5	1.5	1.0	-	-
3	2.0	1.5	1.0	-	-
4	3.0	3.0	1.0	5.0	0.4 A
5	4.5	3.0	1.0	7.5	0.4 A
6	6.0	3.0	1.0	10.0	0.5 A

A=the area between two pairs of standards

Base jacks

The scaffold is erected on base jacks of type BS, which are adjustable between 55 and 570 mm. This means that it is always possible to adjust the standards so as to make the beams level.

Beams

The scaffold is erected using LB AL or ERB AL beams as ledger and/or transom beams with 2.0 m between the lifts. Each lift must be provided with beams on both the inside and outside. The bottom lift must always be placed at the lowest possible level.

Decking

HAKI decking units are used for decking. These are available in all bay sizes and with widths of 400 and 600 mm.

Alternatively, HAKI aluminium planks may be used. These units are available in all bay sizes and with widths of 170, 200, 230, 295 and 320 mm.

Further alternatives are aluminium or wooden gratings. These are intended for bay widths of 1250 or 1655 mm. The gratings are laid on the scaffolding ledgers, transverse to the scaffold.

Decking may also be done using 195 x 50 mm scaffold planks, class K24.

Load classes decking

Decking	Width [mm]	Length [mm]	Load class
Decking unit light	400, 600	1050 - 3050	3
AL plank	170 - 230	1050 - 2500	6
		3050	5
	295 - 320	1050 - 2050	6
		2500	5
		3050	4

Bracing and tying-in

Vertical diagonal bracing between the outside standards must be installed in every 5th bay and always in the end bays. SKRD guardrail frames can replace vertical diagonal braces, but must then be fitted in each bay and at every lift level, including the bottom level.

Plan braces must be fitted in every 5th bay and always in the end bays at every 12th metre in height.

Each inside standard must be tied to the facade or equivalent at every 4th metre in height adjacent to the node between standard and beam. The lowest tie must be fitted no more than 4.8 m above ground level. There must be ties that can carry horizontal forces on at least every 5th pair of standards along the scaffold and at every level of ties.

In addition, we recommend that the scaffold always be anchored as high up as possible.

Where there are brackets, the scaffold must be anchored at the level of the brackets.

Scaffold with lattice beams must be anchored at the fixing points of the beams.

The following estimated maximum loads apply to scaffolding of this type of 24 m in height in accordance with EN 12811. Ties that can withstand horizontal forces should be dimensioned for a load of 4.7 kN parallel with the façade and 5.7 kN perpendicular to the façade. Other ties should be dimensioned for a load of 3.9 kN perpendicular to the façade.

Where a scaffold is covered in sheeting, the number of ties must be increased to take account of wind load. Separate calculations are therefore required.

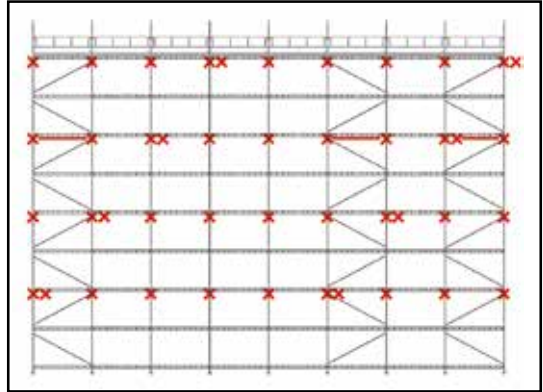

Bracing with vertical diagonal braces and tying-in

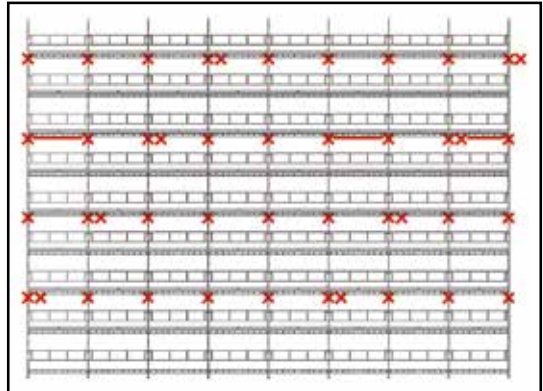

Bracing with SKRD guardrail frames and tying-in

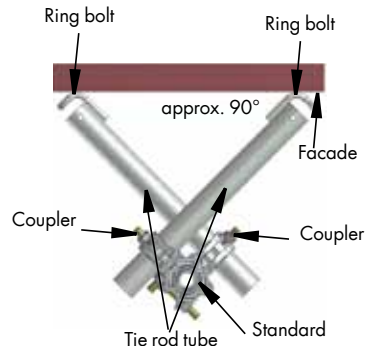

Examples of ties that can carry horizontal forces.
(PLEASE NOTE: use type examined couplers)

Permissible loads on standards

When calculating permissible construction heights for the scaffold, the following permissible loads on standards can be applied for different combinations of lift height and vertical distances between ties.

Lift height [m]	Vertical distance between ties [m]	Permissible standard load [kN]		
		Base jack max.	Base jack min.	Vertically braced using SKRD
2.0	2.0	16.4	20.9	16.4
	4.0	9.5	9.8	9.5

1 kN = 100 kp

The support surface must be capable of withstanding a design load per standard of twice the relevant permitted load on a standard.

When scaffolding is suspended, standard joints must be locked using 16 mm pins. The permissible tensile load on a standard in a suspended scaffold is 20.0 kN.

When designing using the partial coefficient method, the design bearing capacity is obtained by multiplying the permitted load by 1.5.

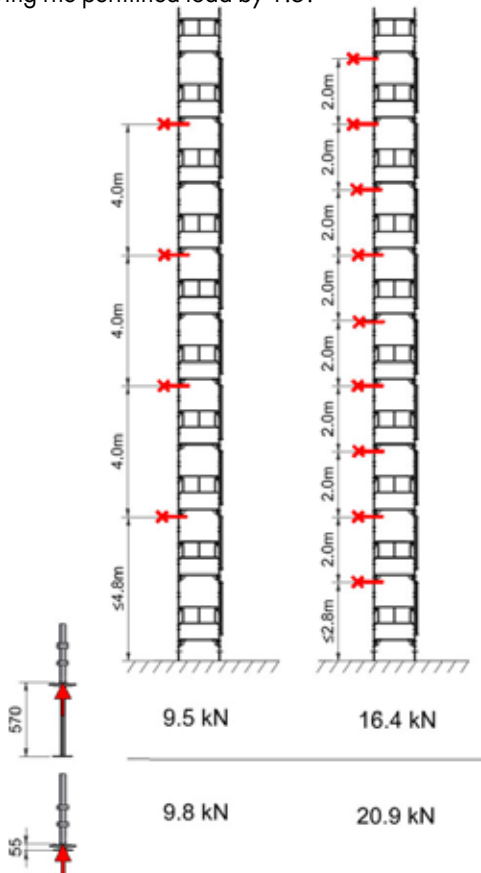

Permissible construction heights

The table applies to HAKI Universal Aluminium with bay lengths 3050 mm, lift heights 2.0 m, and vertical distances between ties of 2.0 or 4.0 m.

Work must not be carried out on more than one lift at a time.

Decking has been calculated at 16.5 kg/m².

HAKI recommends a bay width of at least 1.0 m for load classes 4, 5 and 6.

Other bay lengths, bay widths and decking alternatives will have an effect on the permissible construction height. Please contact HAKI's technical department in these cases.

Permissible construction heights for HAKI Universal Aluminium

Vertical distance between ties [m]	Decking	Width [mm]	Number of decked levels	Load class				
				1	2	3	4	5
2.0	AL plank load class 5 16.5 kg/m ²	700	1	190	182	176	164	148
			5	172	160	152	134	110
			All	68	64	60	54	46
		770	1	188	178	172	160	142
			5	168	154	146	128	100
			All	66	60	56	50	40
		1050	1	182	168	160	144	—
			5	158	138	126	100	—
			All	54	48	44	36	—
		1250	1	176	162	152	—	—
			5	150	126	112	—	—
			All	48	42	38	—	—
4.0	AL plank load class 5 16.5 kg/m ²	700	1	102	94	88	76	60
			5	84	72	64	46	22
			All	36	32	28	22	12
		770	1	100	90	84	72	54
			5	82	68	58	40	14
			All	34	28	26	20	10
		1050	1	94	82	74	58	—
			5	70	52	40	14	—
			All	26	22	18	10	—
		1250	1	90	76	66	—	—
			5	64	42	26	—	—
			All	24	16	12	—	—

1 kN = 100 kp

Permissible load classes for different beam combinations

The tables apply to HAKI Universal Aluminium LB AL or ERB AL beams for varying bay sizes, decking of weight 16.5 kg/m² and unilateral or bilateral loading.

In the specified load classes, no consideration has been paid to the bearing capacity of the decking.

Permissible load classes for LB AL beam for unilateral loading

Ledger beam LB AL	a [m]							
	700	770	1050	1250	1655	1964	2500	3050
LB 350	6	6	6	6	6	6	6	6
LB 770	6	6	6	6	6	6	6	6
LB 1050	6	6	6	6	6	6	6	6
LB 1250	6	6	6	6	6	6	6	6
LB 1655	6	6	6	6	6	6	5	5
LB 1964	6	6	6	6	6	6	5	5
LB 2500	6	6	6	6	5	5	4	3
LB 3050	6	6	6	5	5	4	4	3

Permissible load classes for ERB AL beam for unilateral loading

Single tube beam ERB AL	a [m]								
	564	700	770	1050	1250	1655	1964	2500	3050
ERB 564	6	6	6	6	6	6	6	6	6
ERB 700	6	6	6	6	6	6	6	6	6
ERB 770	6	6	6	6	6	6	6	6	6
ERB 1050	6	6	6	6	6	6	6	6	6
ERB 1250	6	6	6	6	6	6	6	6	5
ERB 1655	6	6	6	6	6	5	5	4	4
ERB 1964	6	6	6	5	5	4	4	3	3
ERB 2500	6	5	5	4	4	3	3	3	2
ERB 3050	6	4	4	3	3	3	2	1	1

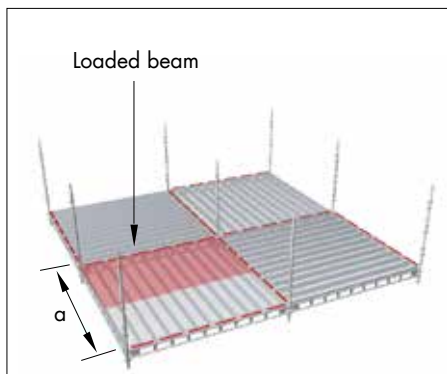

Wide scaffold

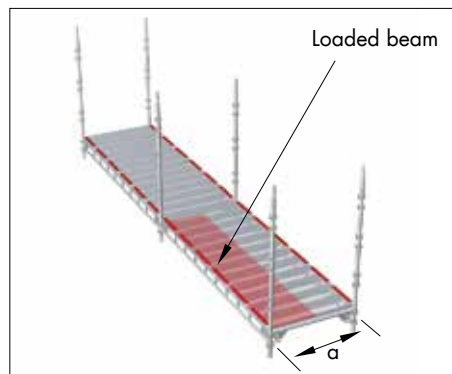

Facade scaffold

Permissible load classes for LB AL beam for bilateral loading

Ledger beam LB AL	a [m]							
	700	770	1050	1250	1655	1964	2500	3050
LB 350	6	6	6	6	6	6	6	6
LB 770	6	6	6	6	6	6	5	5
LB 1050	6	6	6	6	5	5	4	4
LB 1250	6	6	6	6	5	5	4	3
LB 1655	6	6	5	5	4	4	3	3
LB 1964	6	6	5	5	4	4	3	3
LB 2500	5	5	4	4	3	3	3	3
LB 3050	5	5	4	3	3	3	2	–

Permissible load classes for ERB AL beam for bilateral loading

Single tube beam ERB AL	a [m]								
	564	700	770	1050	1250	1655	1964	2500	3050
ERB 564	6	6	6	6	6	6	6	6	6
ERB 700	6	6	6	6	6	6	6	5	5
ERB 770	6	6	6	6	6	6	6	5	5
ERB 1050	6	6	6	6	6	5	5	4	4
ERB 1250	6	6	6	6	6	5	5	4	3
ERB 1655	6	5	5	5	4	3	3	3	2
ERB 1964	6	4	4	3	3	3	2	1	1
ERB 2500	5	4	3	3	3	2	1	1	1
ERB 3050	4	3	3	2	1	1	1	–	–

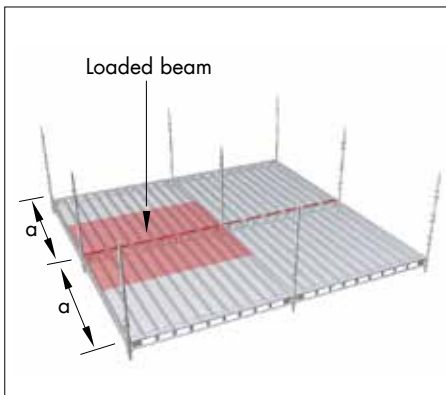

Wide scaffold

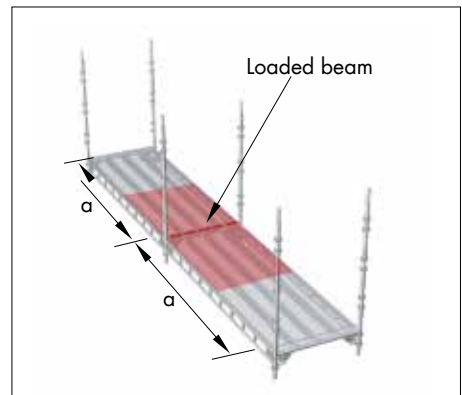

Facade scaffold

Permissible loads on beams

Permissible loads on beams installed in HAKI standards.

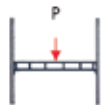
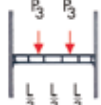
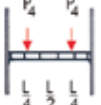
					
Beam type	Permissible load q [kN/m]	Permissible distributed load Q [kN]	Permissible centrepoint loads P [kN]	Permissible point loads P ₃ [kN]	Permissible point loads P ₄ [kN]
LB 350 AL	141.8	42.5	42.5	21.3	21.3
LB 770 AL	59.1	42.5	30.1	21.3	21.3
LB 1050 AL	42.5	42.5	21.7	16.3	21.3
LB 1250 AL	30.1	36.1	18.1	13.6	18.1
LB 1655 AL	16.8	27.0	13.5	10.1	13.5
LB 1964 AL	11.8	22.6	11.3	8.5	11.3
LB 2500 AL	7.2	17.6	8.8	6.6	8.8
LB 3050 AL	4.8	14.4	7.2	5.4	7.2
ERB 700 AL	26.2	17.0	8.5	6.4	8.5
ERB 770 AL	23.6	17.0	8.5	6.4	8.5
ERB 1050 AL	17.0	17.0	8.5	6.4	8.5
ERB 1250 AL	11.8	14.2	7.1	5.3	7.1
ERB 1655 AL	5.6	9.0	4.5	3.4	4.5
ERB 1964 AL	3.8	7.3	3.7	2.8	3.7
ERB 2500 AL	2.4	6.0	3.0	2.3	3.0
ERB 3050 AL	1.6	4.7	2.4	1.8	2.4

1 kN = 100 kp

Brackets

Each level at which a bracket is fitted must be provided with a wall tie.

Load classes for brackets apply provided that the brackets are fitted in a bay of length max. 3050 mm and in connection with decking of weight 16.5 kg/m².

In the specified weight classes, no consideration has been paid to the bearing capacity of the decking. The permissible load class can never be greater than the load class for the decking.

Bracket	Load class
SK 230 AL	6
SK 460 AL	4
SK 564 AL	3
SK 770 AL	3
SK 1250 AL	3

Access ways

Access is usually provided by means of HAKI UTV AL stairways that are fitted to the outside of the scaffold using components designed for this purpose. When an external stairway is fitted in accordance with the directions on page 13, the loads on standards should not be reduced.

Alternatively, a HAKI tower scaffold may be used, see User's Manual HAKI Stair Tower. Ascent via ladders may be arranged by means of HAKI decking units with trapdoors and ladders, or HAKI STV ladders.

Lattice beams

Lattice beams of aluminium

Aluminium lattice beams are fitted in pairs on the inside and outside of the scaffold. Both the top and bottom tubes must be fixed to the standards using SW 48x48 swivel couplers. The height is adjusted so that the decking is horizontal when this is installed.

The lattice beams must be braced against lateral movement using a diagonally rigid framework of standards and beams or tubes and couplers.

When erecting as in the illustration with ledger beams and horizontal diagonals, the greatest permitted load on a standard is 14.7 kN at the centre of the lattice beam. Vertical diagonal bracing must be carried out between the outer standards in both bays beside the beam.

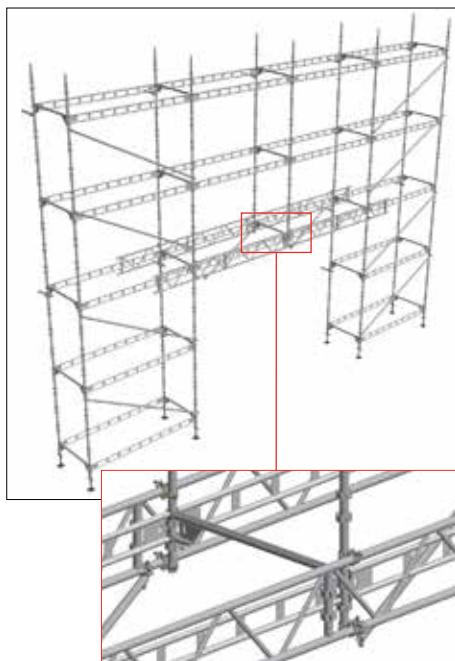

Permissible loads on lattice beams

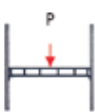
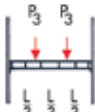
				
Lattice beam	Permissible load q [kN/m]	Permissible distributed load Q [kN]	Permissible centrepoint load P [kN]	Permissible point loads P_3 [kN]
Aluminium				
FB 4100 AL	4.9	19.4	7.5	7.5
FB 6100 AL	3.0	18.3	7.5	6.9
FB 8100 AL	1.7	13.7	6.9	5.1

Maintenance & storage

1. After use, all components must be thoroughly cleaned and inspected before storage.
2. Any damaged parts or components found must be replaced.
3. The manufacturer or supplier must be consulted before repairing scaffold material.
4. Components must be sorted and stacked properly. Take care not to pile the stacks too high, so that the material lower down in the stacks becomes overloaded and damaged. If the material must be stacked up high, suitable racking and shelves should be used.
5. Wooden and plastic components (e.g. platforms, toe boards, toe board holders, etc.) should be stored in a sheltered area so as to maximize their working life.

Wind, ice and snow

Since extreme weather conditions may occur during winter months, it is important to remove snow and ice immediately.

With regards to wind loads, ties must be installed every fourth metre in height; see the section "Bracing and tying-in". For clad scaffolding, calculations should be made in each individual case.

For more information, please contact HAKI's technical department.

Alternative methods of erection when guardrail is fitted in advance



In order to be able to fit guardrails prior to decking, using HAKI's advance guardrail tool or with the aid of other guardrail fitting devices, the external standards must be one metre higher than the next lift. Some alternative methods of erection to achieve this are shown here.

These methods of erection also facilitate the use of temporary guardrails.

For permissible loads on standards, see page 16.

In other respects, see instructions for the fitting devices in question.

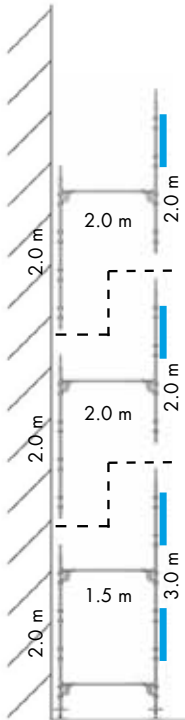

With a first lift height of 1.5 m, start with a 2.0 m standard internally and a 3.0 m standard externally. Continue with lift heights of 2.0 m, using 2.0 m standards both internally and externally.

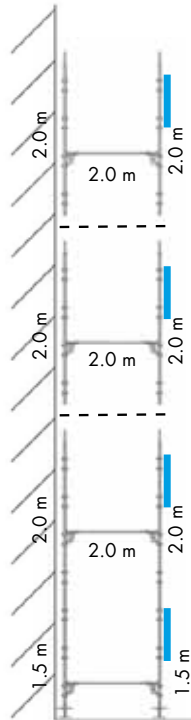

With lift heights of 2.0 m, start with a 1.5 m standard both internally and externally. Continue with 2.0 m standards both internally and externally.

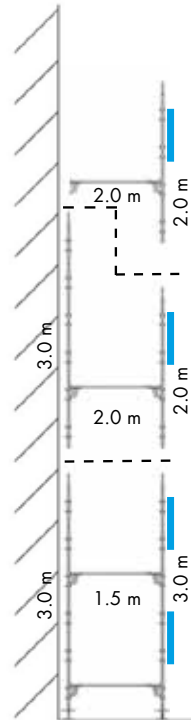

With a first lift height of 1.5 m, start with 3.0 m standards both internally and externally. Continue with lift heights of 2.0 m, using 3.0 m standards internally and 2.0 m standards externally.

Attachment points for personal fall protection equipment

Permissible points of attachment for personal fall protection equipment are as described below.

PLEASE NOTE: Recommendations for points of attachment apply provided that the component in question is otherwise without load and that only one person is attached to the same component at any one time. Components that have been subjected to loading from fall protection equipment must be scrapped and replaced by new material.

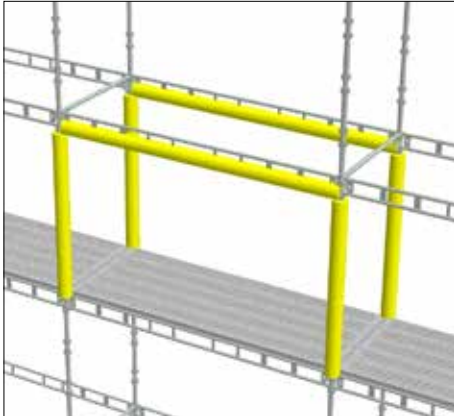

Around a standard between two lifts or around the lower tube in a ledger beam LB AL fitted between two standards.

PLEASE NOTE: It is not permissible to attach around a HAKI Universal Aluminium single tube beam ERB AL.

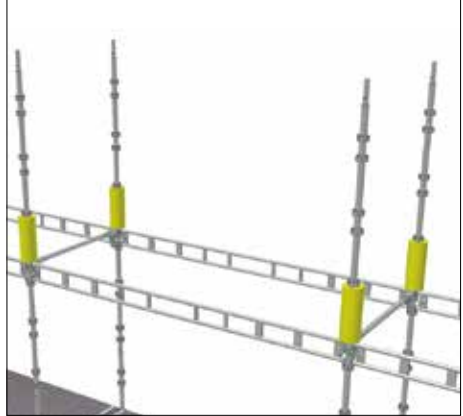

Around a free standard, but only within 40 cm of the node.

PLEASE NOTE: Not next to a standard joint.

No other points of attachment can be recommended. Fall protection equipment **MUST NOT** be attached to guardrails, brackets and cantilevers, i.e. beams fixed at only one end. Fall protection equipment **MUST NOT** be attached to components that have not been locked into place.

PLEASE NOTE: Use only approved safety equipment.

Notes

SAFETY CHECKLIST

1. Supporting surface checked with regard to load-bearing capacity
2. Distance to wall or similar as short as possible
3. Scaffold aligned correctly horizontally and vertically
4. Components correctly fitted and locked
5. Bracing correctly fitted
6. Anchoring with right number and placing of ties
7. Decking correctly fitted
8. Guardrail with toeboard if drop is two metres or more
9. Suitable means of access to scaffold
10. Scaffold erected for correct class of load

