

USER'S MANUAL HAKI SHORING TOWER

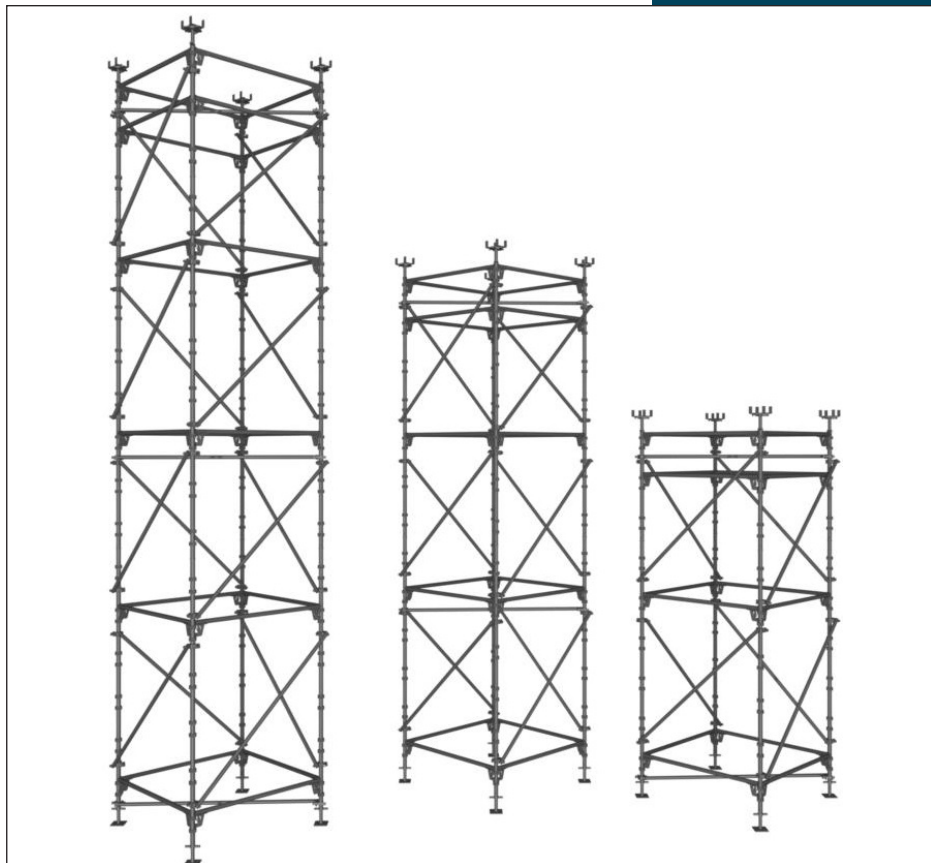

Important information

HAKI's product liability and user's manuals apply only to scaffolds that are entirely composed of components that have been made and supplied by HAKI.

HAKI's scaffold systems must not be erected using components of makes other than HAKI or be connected to scaffolds of makes other than HAKI. In such cases, a special study of load-bearing capacity must be carried out. However, HAKI has no objection to the customary addition of scaffold tubes and approved couplers to the scaffold.

Adding components from different suppliers may invalidate the insurance cover.

This user's manual is based on a minimum of 2 competent erectors wearing safety harnesses with twin tail lanyards.

This user's manual is to be used in conjunction with HAKI training courses.













HAKI reserves the right to make technical modifications on a continual basis.

The latest versions of HAKI user's manuals can be downloaded from our website, www.HAKI.com.

For scaffold structures that are not covered by this user's manual, please contact HAKI's technical department.

HAKI colour code

Horizontals and diagonals are marked with their nominal sizes (bay sizes) and a colour code. The marking is a useful means of identification when erecting and handling the scaffold material.

564		1050		1964		3050	
700		1250		2050			
770		1550		2500			
1010		1655		2550			

Forces and dimensions

1000 N = 1 kN ~ 100 kg

10 N ~ 1 kg

All measurements in mm

HAKI Shoring

The HAKI Shoring Tower has been designed to conform to current European standards. The loading criteria contained in this manual is calculated according to current European design standards, SS-EN 12812, and SS-EN 12813.

The calculations include wind loads and vertical loads. Structural imperfections from the tolerance of component joints is also taken into account according to EN 12812, EN 12813 and EN 1993-1-1.

Restraint ties to the top lift are assumed to be very rigid. In analysis, they are estimated to take up to 10 kN in both directions of the horizontal plane.

The Contractor must check that all horizontal forces from the Shoring Towers can be transferred and resisted by the permanent or other temporary construction. It is the Contractor's responsibility to ensure that the foundation can withstand all loads from the Shoring Tower.

General

HAKI Shoring Towers consist of HAKI Universal standards, single ledger beams, diagonal braces, horizontal braces, base jacks and fork heads. All components are hot-dip galvanized.

HAKI Shoring Towers are erected with beam lengths of 1250 or 1655mm and with 1500 or 2000 mm between lifts. They can be erected as free-standing towers or tied at the top lift to an adjacent scaffolding or staging.

HAKI Shoring Towers can be adapted to different heights by adjusting the base jacks at both the top and bottom.

Marking

All components, with the exception of locking catches, locking pins etc, come permanently marked with the HAKI logo and the last two figures of the year of manufacture (S22).

All load bearing components are marked for full traceability.







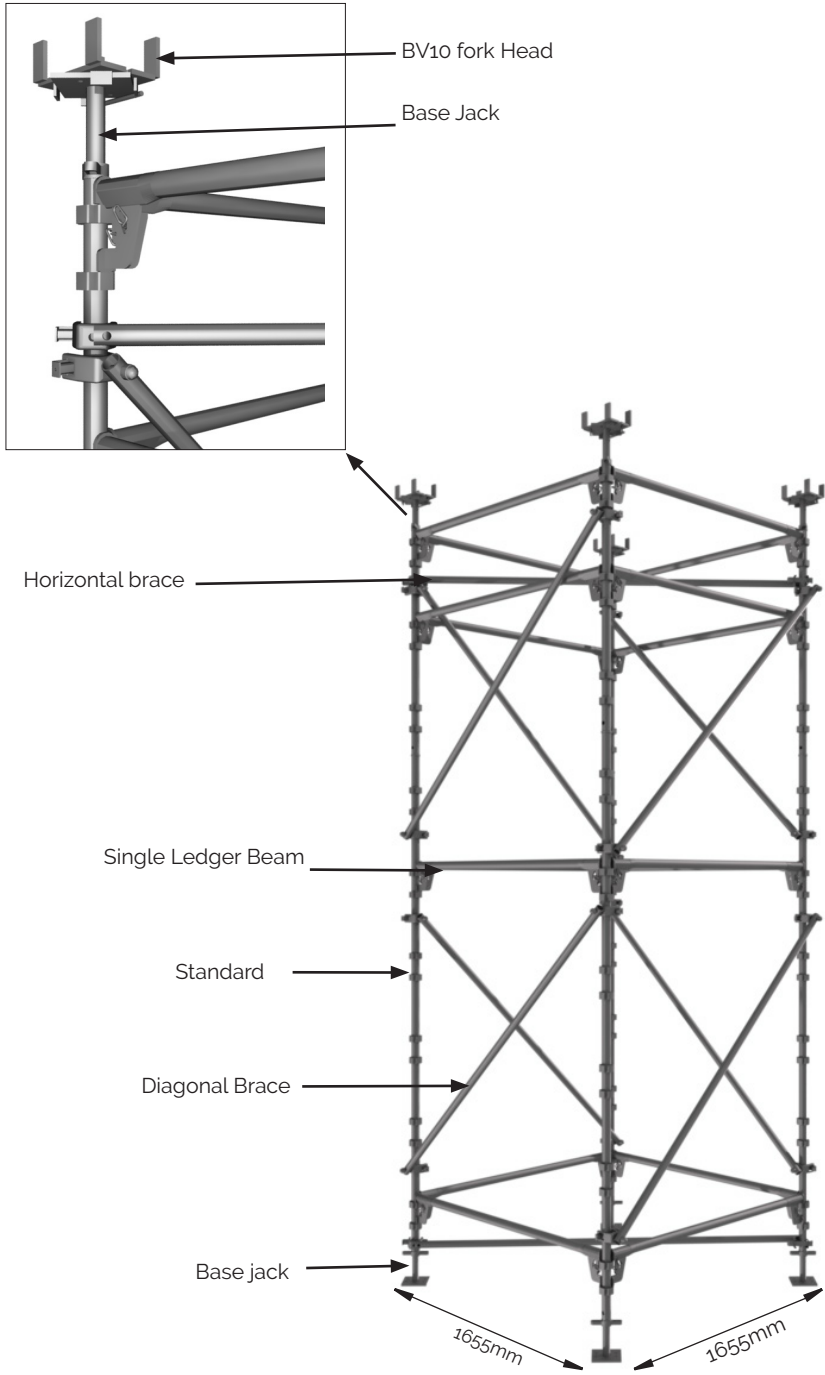

IMPORTANT!

**ENGAGE LOCKING CATCHES AS
EACH COMPONENT IS FIXED**

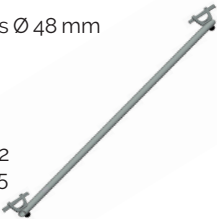



Name		Code/Data	Item No.	Weight(kg)
Base jack BS Adjustable 55-570 mm			2071000	5.0
Standard S Standard joint with spigot Pockets at same level Ø 48 mm		500 1000 1500 2000 3000	7016050 7016100 7016150 7016200 7016300	2.9 5.3 7.7 10.1 15.2
Open-ended Standard SC Standard joint without spigot Pockets at same level Ø 48 mm		853 1353 1853	7011104 7011154 7011204	4.8 7.3 9.8
Diagonal Brace DS With wedge couplers Ø 48 mm				
DS 1250 L=1954 DS 1655 L=2235		1250 1655	7122124 7122164	9.0 10.1
DS 1250x1500 L=1602 DS 1655x1500 L=1935		1250x1500 1655x1500	7122125 7122165	9.0 10.1
Ledger Beam LBL With spring locking catch Ø 34 mm		1250 1655	7021122 7021162	6.5 6.7
Single Ledger ERB With spring locking catch Ø 48mm		1250 1655	7022121 7022161	5.1 6.3

Name		Code/Data	Item No.	Weight(kg)
Horizontal Brace		1250x1250	7141010	8,5
		1655x1655	7141005	10,5

Fork Head BV 10			7155000	3,0
---------------------------	-----------------------------------------------------------------------------------	--	----------------	-----

Pin & Chain 16mm Steel Ø 16 mm			5141257	0,3
----------------------------------------------	-----------------------------------------------------------------------------------	--	----------------	-----

For reinforcing standard joint
in connection with tensile load.

Erection Accessories

Name		Code/Data	Item No.	Weight(kg)
Light Deck AL Load class 3 (2.0 kN/m ²)		1250x600	4071122	10,6
		1655x600	4071162	13,5

Decking unit with hatch		1655x600	4071163	14,7
--------------------------------	------------------------------------------------------------------------------------	----------	----------------	------

Guardrail Frame GFL		1250	7052124	5,7
		1655	7052164	7,4

Advanced Guardrail Tool			4052001	1,4
--------------------------------	-------------------------------------------------------------------------------------	--	----------------	-----

For other accessories, see HAKI Component List

Information on safety when erecting and dismantling

1. Before erecting or dismantling a scaffold, the working area should be fenced off where possible.
2. The location for the scaffold must be checked in order to prevent risks when erecting, dismantling and moving the scaffold and to ensure that work can be carried out safely with regard to level and slope, obstacles and wind conditions.
3. Make sure that all lifting equipment to be used, e.g. chain hoists, lifting ropes, pulley blocks, etc., has been thoroughly tested and approved by an authorized person in accordance with local regulations.
4. Check that tools and protective equipment are available at the worksite.
5. Wear appropriate personal safety equipment at all times, e.g. safety harnesses, proper independent lifelines with suitable fixings, etc.
6. When erecting and dismantling a scaffold, robust temporary decking must be used as temporary platforms for the scaffolders.
7. Always make sure that the safety locking devices that prevent a platform lifting off have been activated once a platform has been installed.
8. Study all relevant instructions or safety directions from the manufacturers of the various scaffolds that are to be used.
9. Never climb up a scaffold from the outside. Always use the stairs, ladders or climbing frames that are designed to provide access to the upper decks from the inside of the scaffold.
10. If the scaffold is located outdoors, erection or dismantling work must be discontinued in severe weather conditions. All loose components and materials must be secured prior to leaving the scaffold.
11. All scaffolding work must be undertaken by competent operatives under the supervision of a competent person.
12. Raising and lowering of parts, material and tools using ropes or slings must be carried out in a protected lifting area.
13. Lifting equipment must not be fitted to scaffolding unless ties or equivalent devices are secure.
14. Beware of any overhead power lines nearby.
15. Always observe and comply with the regulations issued by the local authorities concerned.
16. Operatives should always be clipped to a single ledger or ledger beam during erection/dismantling. Reference should be made to the "Personal Safety Equipment" section in the HAKI Universal User manual.

Before erecting the HAKI Shoring Towers, check and flatten out the ground. The ground must be flat for even settlement of the base lift. The ground's bearing capacity may be improved with the help of sole pads.

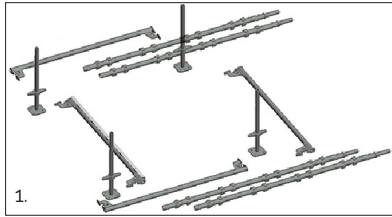

1. Lay out material to form base lift.

Position base jacks on sole pads, at the position of standards.

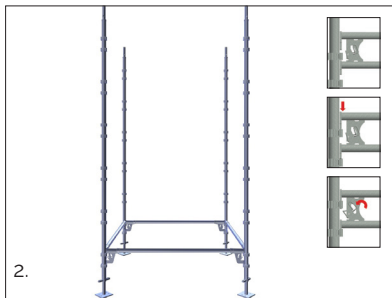

2. Install the first standard and fit single ledgers in both the transverse and longitudinal directions.

Ledgers must be fitted to the lowest group of pockets on the standard.

Install remaining standards and single ledgers in order to complete the first lift.

Lock the beams into position.

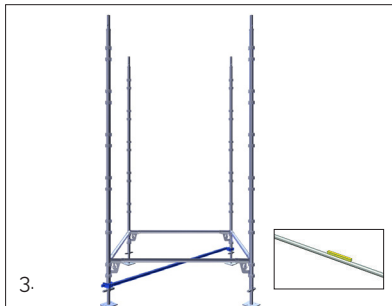

3. Install a horizontal brace under the lowest group of pockets on the standards as shown.

Level the bay until it is squared off and lock the horizontal brace wedge.

Check the levels in both the transverse and longitudinal directions using a spirit level and adjust using the base jacks.

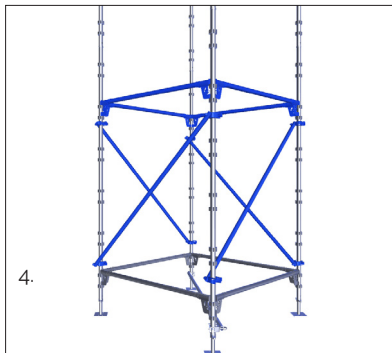

4. Install a second level of single ledgers at either 1500 or 2000mm, depending on the tower configuration, above the first set of single ledgers. The tower configuration depends on the loading condition shown on pages 12 and 14.

Install diagonal braces around all 4 sides of the Shoring Tower and correct the vertical alignment of the standards.

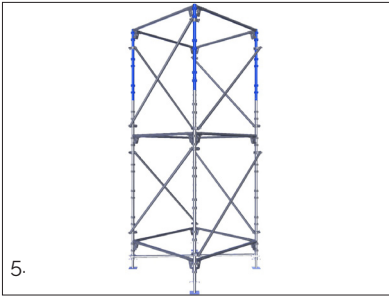

5. With the aid of erection platforms, install the next set of standards, single ledgers, and diagonal braces for the second lift.

NOTE 1: The standards on the top of the Shoring Tower must be open-ended standards.

NOTE 2: The top lift of the Shoring Tower must be a 1500mm lift. Extra single ledgers are necessary if lower lifts are 2000mm.

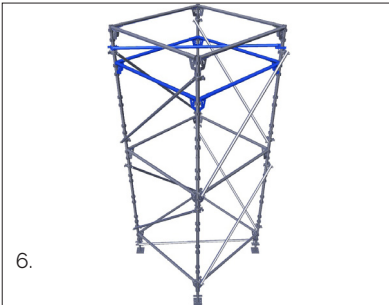

6. Where required, as per NOTE 2 in step 5, install the extra set of single ledgers 500mm below the top single ledgers.

Install horizontal braces every 3000mm if the Shoring Tower has a 1500mm lift configuration and every 4000mm for a 2000mm lift configuration.

If needed, continue erection up to the desired height as per steps 4, 5 and 6.

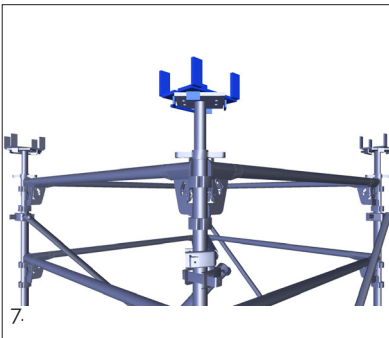

7. Install inverted base jacks and BV10 fork heads on the base jacks.

Check the levels in both the transverse and longitudinal directions and adjust using the base jacks.

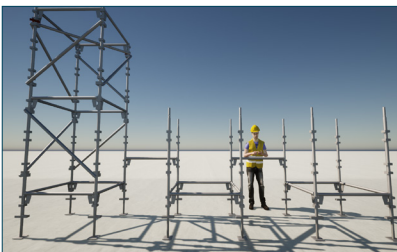

NOTE 3: To erect multiple Shoring Towers use the aid of single ledgers between the Shoring Towers to maintain equal spacing.

NOTE 4: All single ledgers of the Shoring Tower can be replaced with ledger beams.

Information on safety when dismantling

1. Do not throw or drop materials to the ground. This may damage the material or cause personal injury. The materials must be lowered down to the ground by means of ropes or slings or passed down by hand.
2. Dismantle the HAKI shoring tower in the reverse order of the erection procedure.
3. Always observe and comply with the regulations published by the local authorities concerned.
4. Operatives should always be clipped to a single ledger or ledger beam during dismantling.
5. Reference should also be made to section "Information on safety when erecting and dismantling" on page 7 in this manual.

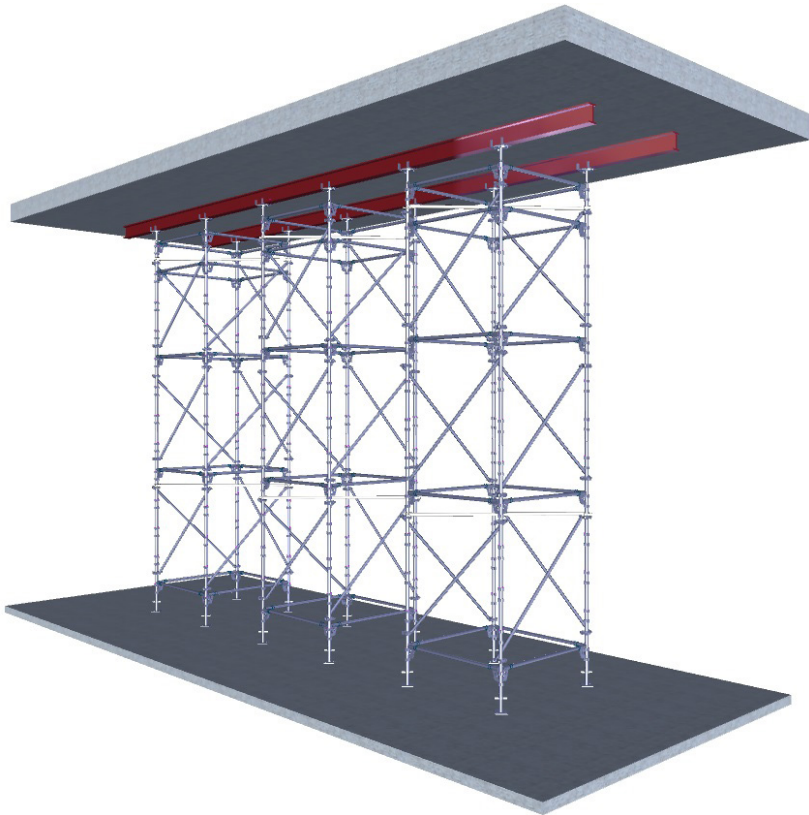

9.0m HAKI Shoring Towers with 2m lifts

Installation of formwork girders

For HAKI Shoring Towers, all types of formwork girders with a maximum width of 135mm can be used on the BV10 fork heads.

Formwork girders must be installed centrally on the BV10 fork heads for an even distribution of the loads. A timber wedge can be used between the BV10 fork head and the formwork girder to centre the formwork girder.

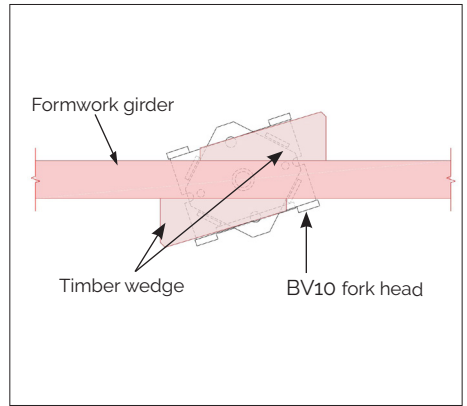
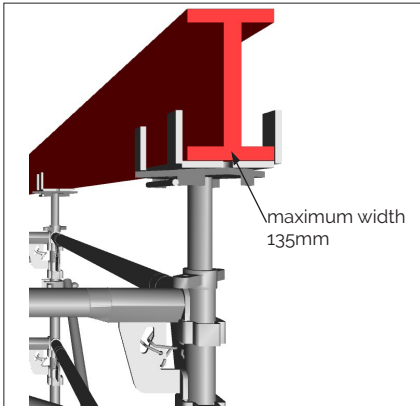

Support of concrete beams

The HAKI Shoring Tower should be placed centrally under concrete beams to distribute the load of each concrete beam on two legs of the Shoring Tower.

For an even load distribution, cross beams can be installed between the main formwork girders and the concrete beams.

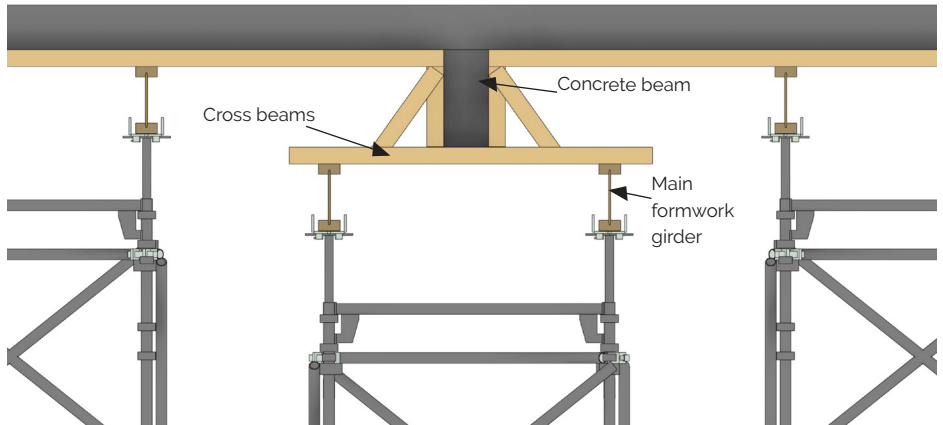

Shoring Towers with 1.5m lifts

Permissible vertical leg load						
Restrained at the top lift -1.5 m lifts						
Wind load	Size plan L1xL2		Maximum extensions for base jack and head jack	Height		
				3.353 m	6.353 m	9.353 m
				1.5+1.853	3+1.5+1.853	3+3+1.5+1.853
				V (kN)	V (kN)	V (kN)
0.8 kN/m ²	1250	1250	≤ 325 mm	24	22	20
			570 mm (max.)	20	18	16
	1655	1655	≤ 325 mm	24	22	20
			570 mm (max.)	20	18	16

Permissible vertical leg load						
Free standing with horizontal load -1.5 m lifts						
Wind load	Size plan L1xL2		Maximum extensions for base jack and head jack	Height		
				3.353 m	6.353 m	9.353 m
				1.5+1.853	3+1.5+1.853	3+3+1.5+1.853
				V (kN)	V (kN)	V (kN)
0.8 kN/m ²	1250	1250	≤ 325 mm	9	8	7
			570 mm (max.)	8	7	5
	1655	1655	≤ 325 mm	9	9	7
			570 mm (max.)	8	7	5

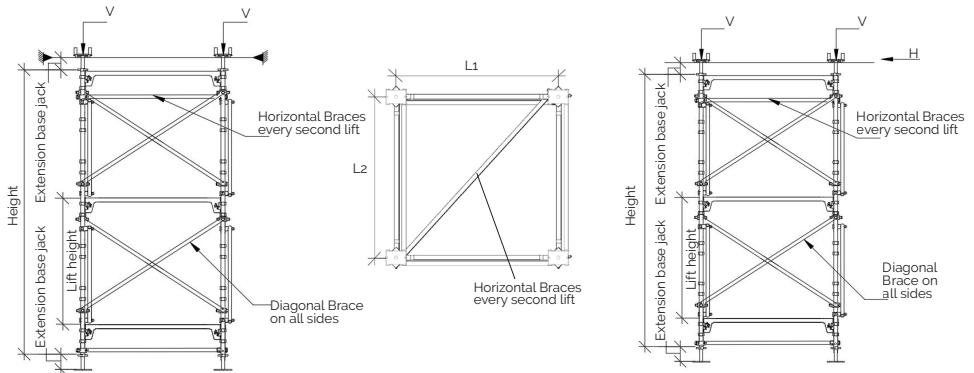

Shoring Tower restrained at the top lift,
subjected to vertical loads

Free standing Shoring Tower,
subjected to vertical and horizontal loads

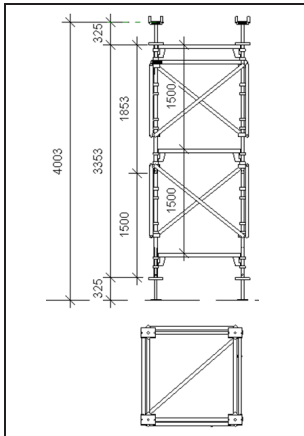
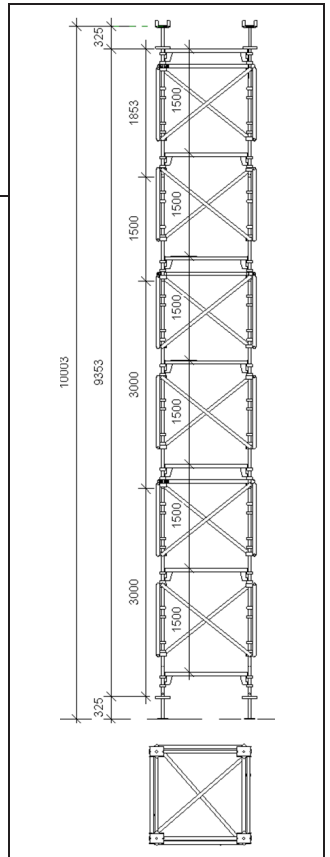
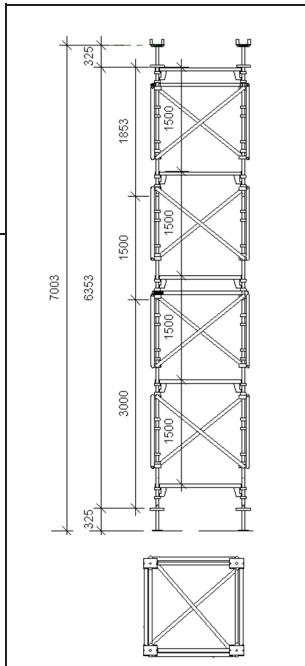
Shoring Towers with 1.5m lifts
Total Height = 10m
Total Height = 4m

Total Height = 7m

	Item No	Unit	HAKI Description	Item No	Unit	HAKI Description	Item No	Unit	HAKI Description
1250x1250	2071000	8	Base jack	2071000	8	Base jack	2071000	8	Base jack
	7011204	4	Standard SC 1853	7011204	4	Standard SC 1853	7011204	4	Standard SC 1853
	7016150	4	Standard S 1500	7016150	4	Standard S 1500	7016150	4	Standard S 1500
	7022121	12	Single Ledger ERB 1250	7016300	4	Standard S 3000	7016300	8	Standard S 3000
	7122124	8	Diagonal Brace DS 1250x1500	7022121	20	Single Ledger ERB 1250	7022121	28	Single Ledger ERB 1250
	7141010	1	Horizontal Brace 1250x1250	7122124	16	Diagonal Brace DS 1250x1500	7122124	24	Diagonal Brace DS 1250x1500
	7155000	4	Fork Head BV 10	7141010	2	Horizontal Brace 1250x1250	7141010	3	Horizontal Brace 1250x1250
				7155000	4	Fork Head BV 10	7155000	4	Fork Head BV 10
1655x1655	2071000	8	Base jack	2071000	8	Base jack	2071000	8	Base jack
	7011204	4	Standard SC 1853	7011204	4	Standard SC 1853	7011204	4	Standard SC 1853
	7016150	4	Standard S 1500	7016150	4	Standard S 1500	7016150	4	Standard S 1500
	7022161	12	Single Ledger ERB 1655	7016300	4	Standard S 3000	7016300	8	Standard S 3000
	7122164	8	Diagonal Brace DS 1655x1500	7022161	20	Single Ledger ERB 1655	7022161	28	Single Ledger ERB 1655
	7141005	1	Horizontal Brace 1655x1655	7122164	16	Diagonal Brace DS 1655x1500	7122164	24	Diagonal Brace DS 1655x1500
	7155000	4	Fork Head BV 10	7141005	2	Horizontal Brace 1655x1655	7141005	3	Horizontal Brace 1655x1655
				7155000	4	Fork Head BV 10	7155000	4	Fork Head BV 10

Shoring Towers with 2.0m lifts

Permissible vertical leg load						
Restrained at the top lift - 2.0m lifts (top lift 1.5m)						
Wind load	Size plan L1xL2		Maximum extensions for base jack and head jack	Height		
				4.353 m	6.353 m	8.353 m
				2+1.5+0.853	2+2+1.5+0.853	2+2+2+1.5+0.853
				V (kN)	V (kN)	V (kN)
0,8 kN/m ²	1250	1250	≤ 325 mm	21	19	17
			570 mm (max.)	16	16	14
	1655	1655	≤ 325 mm	30	19	18
			570 mm (max.)	16	16	15

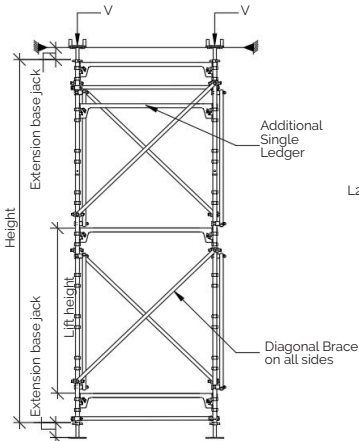
Permissible vertical leg load						
Free standing with horizontal load - 2.0m lifts (top lift 1.5m)						
Wind load	Size plan L1xL2		Maximum extensions for base jack and head jack	Height		
				4.353 m	6.353 m	8.353 m
				2+1.5+0.853	2+2+1.5+0.853	2+2+2+1.5+0.853
				V (kN)	V (kN)	V (kN)
0,8 kN/m ²	1250	1250	≤ 325 mm	9	8	6
			570 mm (max.)	7	6	5
	1655	1655	≤ 325 mm	9	8	6
			570 mm (max.)	7	6	5



Shoring Tower restrained at the top lift, subjected to vertical loads

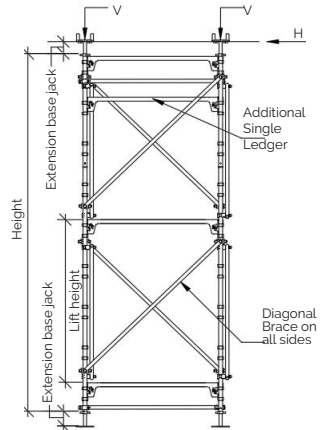

Free standing Shoring Tower, subjected to vertical and horizontal loads

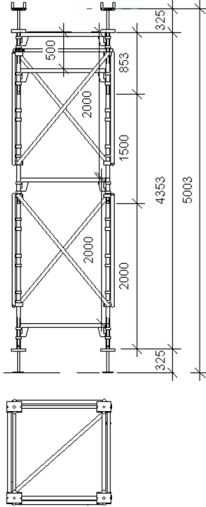
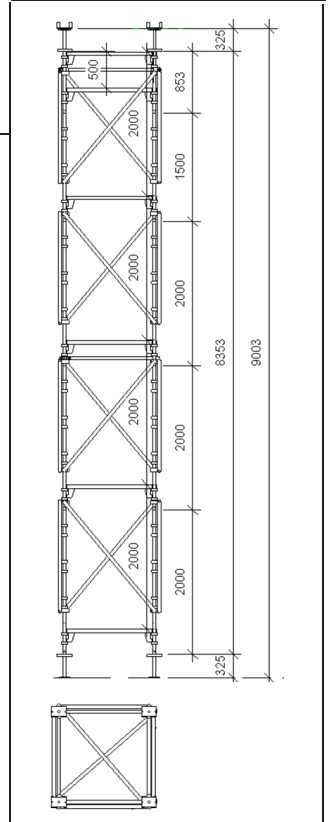
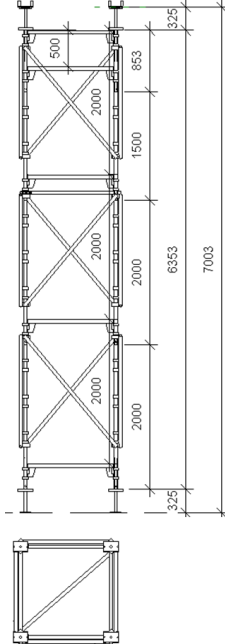
Shoring Towers with 2.0m lifts
Total Height = 9m
Total Height = 5m

Total Height = 7m

	Item No.	Unit	HAKI Description	Item No.	Unit	HAKI Description	Item No.	Unit	HAKI Description
1250x1250	2071000	8	Base jack	2071000	8	Base jack	2071000	8	Base jack
	7011104	4	Standard SC 853	7011104	4	Standard SC 853	7011104	4	Standard SC 853
	7016150	4	Standard S 1500	7016150	4	Standard S 1500	7016150	4	Standard S 1500
	7016200	4	Standard S 2000	7016200	8	Standard S 2000	7016200	12	Standard S 2000
	7022121	16	Single Tube Beam ERB 1250	7022121	20	Single Tube Beam ERB 1250	7022121	24	Single Ledger ERB 1250
	7122124	8	Diagonal Brace DS 1250	7122124	12	Diagonal Brace DS 1250	7122124	16	Diagonal Brace DS 1250
	7141010	1	Horizontal Brace 1250x1250	7141010	1	Horizontal Brace 1250x1250	7141010	2	Horizontal Brace 1250x1250
	7155000	4	Fork Head BV 10	7155000	4	Fork Head BV 10	7155000	4	Fork Head BV 10
1655x1655	2071000	8	Base jack	2071000	8	Base jack	2071000	8	Base jack
	7011104	4	Standard SC 853	7011104	4	Standard SC 853	7011104	4	Standard SC 853
	7016150	4	Standard S 1500	7016150	4	Standard S 1500	7016150	4	Standard S 1500
	7016200	4	Standard S 2000	7016200	8	Standard S 2000	7016200	12	Standard S 2000
	7022161	16	Single Ledger ERB 1655	7022161	20	Single Ledger ERB 1655	7022161	24	Single Ledger ERB 1655
	7122164	8	Diagonal Brace DS 1655	7122164	12	Diagonal Brace DS 1655	7122164	16	Diagonal Brace DS 1655
	7141005	1	Horizontal Brace 1655x1655	7141005	1	Horizontal Brace 1655x1655	7141005	2	Horizontal Brace 1655x1655
	7155000	4	Fork Head BV 10	7155000	4	Fork Head BV 10	7155000	4	Fork Head BV 10

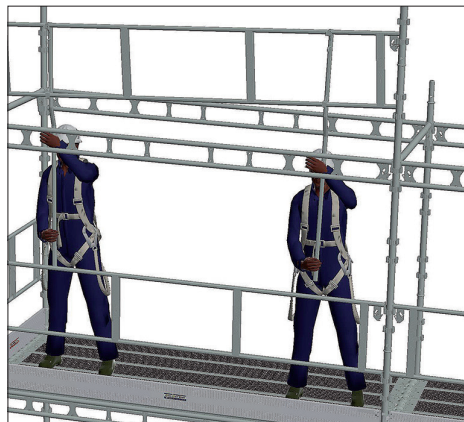
Methods of erection when guardrail frame is fitted in advance



In order to be able to fit guardrail frames prior to the erection of the next lift, use HAKI's advance guardrail(AGR) tool (or the aid of other guardrail fitting devices).

The standards must be one metre higher than the next lift.

For other fitting devices, see HAKI Component List.



Experience

With over 60 years experience to call on, HAKI has gained a leading reputation in its field. With its own R & D and manufacturing facilities, the company now operates throughout Europe and its equipment is in use worldwide. With all products designed and manufactured to ISO 9001:2015, and a comprehensive training and support infrastructure, you can rely on HAKI for support.



Training

The Company's dedicated Training Centre is equipped with the full range of HAKI products where a comprehensive choice of courses is offered. With the benefit of this training, all users of HAKI products can be assured that the equipment is being employed safely and effectively.



Support

From computerised estimating facilities to on site assessment and project back up, HAKI is with its customers every step of the way. Working with HAKI means far more than just proven equipment, it means working with people who understand the scaffolding industry. Whatever the project, the company is committed to ensuring every user enjoys the full benefits associated with the use of HAKI - maximising the savings, profitability, and above all, SAFETY.

Health and Safety at Work Act, 1974

HAKI equipment is designed to meet the requirements of the above Act, Section 6.

It is also the customer's responsibility to comply with the requirements of this Act, particularly to use the equipment in accordance with current codes of practice and in ensuring that components are in good working condition prior to each use.

We are able to provide assistance and advice on matters relating to safe and proper use of HAKI equipment.

